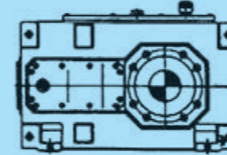
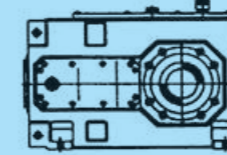
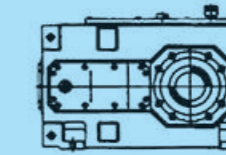
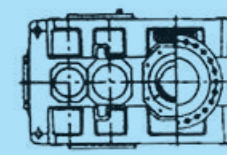
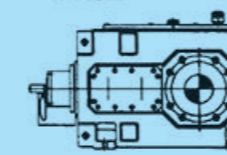
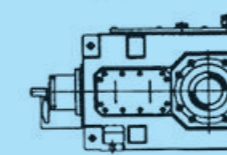
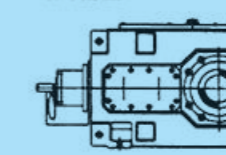
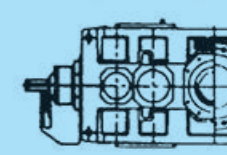
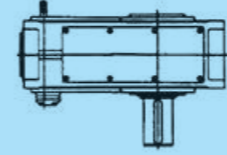
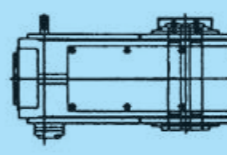
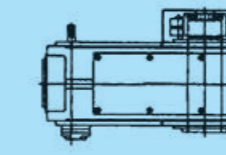
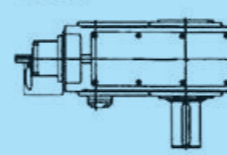
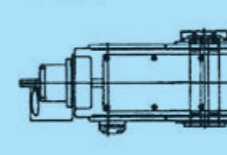
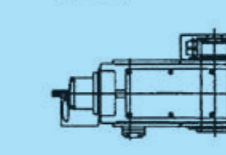

基本类型概述

Summary of Basic Types

卧式安装		Horizontal mounting position	
平行轴齿轮箱 WH1.H, WH2.H, WH3.H, WH4.H 1, 2, 3, 4级, $i_n=1.25-450$		Helical gear units Type WH1.H, WH2.H, WH3.H, WH4.H 1, 2, 3, 4 stage, $i_n=1.25-450$	
WH.SH	WH.HH	WH.DH	WH.HM WH.DM
			
垂直轴齿轮箱 WV2.H, WV3.H, WV4.H 2, 3, 4级, $i_n=5-400$		Bevel-helical gear units Type WV2.H, WV3.H, WV4.H 2, 3, 4级, $i_n=5-400$	
WV.SH	WV.HH	WV.DH	WV.HM WV.DM
			

立式安装		Vertical mounting position	
平行轴齿轮箱 WH2.V, WH3.V, WH4.V 2, 3, 4级, $i_n=6.3-450$		Helical gear units Type WH2.V, WH3.V, WH4.V 2, 3, 4级, $i_n=6.3-450$	
WH.SV	WH.HV	WH.DV	
			
垂直轴齿轮箱 WV2.V, WV3.V, WV4.V 2, 3, 4级, $i_n=5-400$		Bevel-helical gear units Type WV2.V, WV3.V, WV4.V 2, 3, 4级, $i_n=5-400$	
WV.SV	WV.HV	WV.DV	
			

基本类型概述

Summary of Basic Types

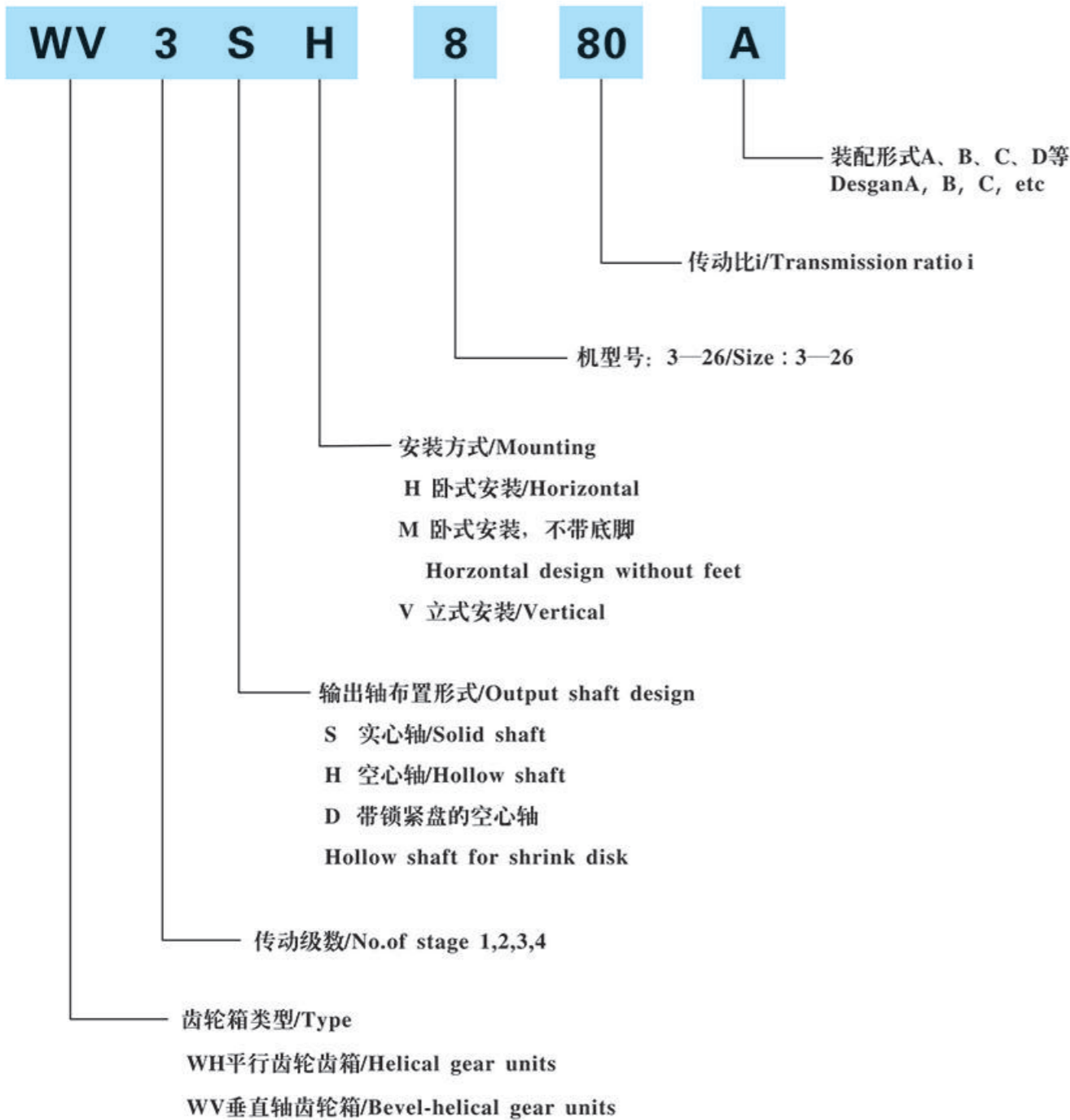

订货时需提供的其他信息:

- 1、齿轮箱标准配置为自然冷却、浸油润滑，如需配置冷却装置或强制润滑时应注明。
- 2、配置逆止器时应注明，并提供输出轴的选择方向（面对输出轴）。
- 3、输入、输出轴轴伸非标，或安装形式不符合标准时（如壁装或倾斜安），需提供简图。

目录

Contents

目录	Contents	页码
产品特征	Characteristic features	4
齿轮箱选型	Selection of gear units	
符号说明	Key to symbols	5
选型指南	Guidelines for the Selection	6
选型示例	Example	7
服务系数	Service Factors	8-9
功率表和热功率表	Tables:Powers and capacities	
WH1SH	WH1SH	10-12
WH2..	WH2..	13-17
WH3..	WH3..	18-22
WH4..	WH4..	23-25
WV2..	WV2..	26-28
WV3..	WV3..	29-34
WV4..	WV4..	35-37
实际传动化	Actual ratios	38-41
允许附加的径向力	Permissible additional radial forces	42-43
装配形式	Assemblies	44
齿轮箱外型安装此尺寸	Gear units install dimensions	
WH1SH	WH1SH	45
WH2.H	WH2.H	46-47
WH3.H	WH3.H	48-49
WH4.H	WH4.H	50-51
WV2.H	WV2.H	52-53
WV3.H	WV3.H	54-55
WV4.H	WV4.H	56-57
WH2.V	WH2.V	58-59
WH3.V	WH3.V	60-61
WH4.V	WH4.V	62-63
WV2.V	WV2.V	64-65
WV3.V	WV3.V	66-67
WV4.V	WV4.V	68-69
冷却盘管尺寸	Gear units cooling coits	70-71
空心轴安装尺寸	Detailes on hollow shafts	
带锁进盘的空心轴	Hollow shafts for shrink disks	72-73
带平键链接的空心轴	Hollow shafts for parallel key connections	74-75

产品特性

Characteristic Features

<p>设计</p> <p>WH. WV 系列齿轮箱参考国外同类产品, 采用全新设计, 主要表现在:</p> <p>1) 高度模块化, 零件种类较少而齿轮箱规格较多。</p> <p>2) 传递功率大, 运转可靠性高。</p>	<p>Design</p> <p>WH. WV series gear units are a completely new design. Advantages are:</p> <p>1) Highly standard modular designed. more Sizes with a reduced variety of parts</p> <p>2) Higher operational reliability combined with increased power capacity.</p>
<p>安装形式</p> <p>WH. WV 系列齿轮箱安装方式灵活, 可卧式或立式安装, 也可按用户要求进行其他形式的安装, 敬请垂询。</p>	<p>Mounting Position</p> <p>The gear units can be supplied for either horizontal or vertical installation. Other arrangements are also possible on request.</p>
<p>使用寿命</p> <p>在正确选型和正常使用、维护的条件下, 齿轮箱(除易损坏件)的主要零部件一般不低于50000小时。</p>	<p>Long service life</p> <p>Under the condition of accurately selecting type size and the normal maintenance and use, main components (except those easily-disabled parts) can last as long as up to more than 50,000 hours.</p>
<p>噪音</p> <p>齿轮箱的主要零部件经过精密加工; 齿轮磨齿加工采用低噪音的修形技术; 采用吸收噪音的箱体结构并通过精心组装和测试; 因而齿轮箱噪音较低。</p>	<p>Lownoise</p> <p>All key components are finished by precisely machining; grinding the gears; designing noise-absorbing housings; accurate assembly and finally tested, and therefore, fairly low noise is reached.</p>
<p>散热性能</p> <p>WH. WV 系列齿轮箱具有较好的散热性能, 主要体现在:</p> <p>1) 齿轮箱具有很高的传动效率</p> <p>2) 设计时增加了箱体的表面积</p> <p>3) 采用大风扇和新型的导流风扇、冷却盘管、油冷却器等多种冷却方式。</p>	<p>Thermal conduction</p> <p>WH. WV series gear units a favourable thermal conduction, because:</p> <p>1) The gear units have a high efficiency.</p> <p>2) Through enlarged housing surface areas.</p> <p>3) Because large fans incorporating a new type of air conduction fan cowl are being used</p>

符号说明

Key to Symbols

<p>符号说明</p> <p>f_1 工作机系数 (表1) 见第8页</p> <p>f_2 原动机系数 (表2) 见第9页</p> <p>f_3 峰值扭矩系数 (表3) 见第9页</p> <p>f_4 环境温度系数 (表4) 见第9页</p> <p>f_5 环境温度系数 (表5) 见第9页</p> <p>f_s 齿轮箱供油系数 对于立式安装齿轮箱见第9页 (表8) 对于卧式安装齿轮箱: $f_s=1$</p> <p>S_r 可靠性系数 (表9)</p> <p>i 实际传动比</p> <p>i_N 公称传动比</p> <p>i_s 要求传动比</p> <p>n_1 输入转速 (rpm)</p> <p>n_2 输出转速 (rpm)</p> <p>P_G 需要的热功率</p> <p>P_{GA} 齿轮箱的基础热功率, 不带辅助冷却装置。</p> <p>P_{GB} 齿轮箱的基础热功率, 带冷却风扇。</p> <p>P_{GC} 齿轮箱的基础热功率, 带内置式冷却盘管。</p> <p>P_{GD} 齿轮箱的基础热功率, 同时带内置式冷却盘管和冷却风扇。</p> <p>P_{2N} 齿轮箱的公称功率 (kW)</p> <p>P_2 工作机的额定功率 (kW)</p> <p>t 环境温度 (°C)</p> <p>T_A 输入轴最大扭, 例如峰值工作扭矩, 起动扭矩或制动扭矩 (N.m)</p> <p>T_{2N} 公称输出扭矩 (kN.m)</p>	<p>Key to Symbols</p> <p>f_1 Factor for driven machine (table 1). Page 8</p> <p>f_2 Factor for prime mover (table 2). Page 9</p> <p>f_3 Peak torque factor (table 3). Page 9</p> <p>f_4 Thermal factors (table 4). Page 9</p> <p>f_5 Thermal factors (table 5). Page 9</p> <p>f_s Oil supply factor for vertical gear units (table 8 page 9). For horizontal gear units: $f_s=1$</p> <p>S_r Safety factor (table 9)</p> <p>I Actual ratio</p> <p>i_N Nominal ratio</p> <p>i_s Required ratio</p> <p>n_1 Input speed (rpm)</p> <p>n_2 Output speed (rpm)</p> <p>P_G Required thermal capacity</p> <p>P_{GA} Thermal capacity for gear units without auxiliary cooling</p> <p>P_{GB} Thermal capacity for gear units with fan cooling</p> <p>P_{GC} Thermal capacity for gear units with built-in cooling coil</p> <p>P_{GD} Thermal capacity for gear units with built-in cooling coil and fan</p> <p>P_{2N} Nominal power rating of gear unit (kW)</p> <p>P_2 Power rating of driven machine (kW)</p> <p>t Ambient temperature (°C)</p> <p>T_A Max. torque occurring on input shaft e.g. peak operating-, starting- or braking torque (N.m)</p> <p>T_{2N} Nominal output torque (kN.m)</p>
--	--

1、确定齿轮箱类型 和规格 Determination of gear unit type and size	1.1 确定传动比 Find the transmission $i_s = n_1/n_2$
	1.2 确定齿轮箱额定功率 Determine nominal power rating of the gear unit $P_{2N} \geq P_2 \cdot F_1 \cdot F_2 \cdot S_r$
	1.3 校核最大扭矩, 例如峰值工作扭矩, 起动扭矩或制动扭矩 Check for maximum torque.e.g.peak operating-.starting-or braking torque $P_{2N} \geq (T_A \cdot n_1/9550) \cdot f_3$ 根据 i_N 和 P_{2N} 在额定功率表中确定的齿轮箱的规格和传动级数 Gear unit sizes and number of reduction stages are given in the rating tables depending on i_N and P_{2N}
	1.4 校核输出轴上允许附加作用力; 见第42和43页 Check whether additional forces on the output shaft are permissible; see page 42 and 43
	1.5 校核实际传动比; 见第38至41页 Check whether the actual ratio i as per tables on page 38 - 41 is acceptable

2、确定润滑方式 Determination of oil supply	安装方式/Mounting position	
	卧式安装/Horizontal	立式安装/Vertical
	可供选择的润滑油供油方式; - 飞溅润滑 - 浸油润滑 所有需润滑的零部件均浸在润滑油中 - 强制润滑 All parts to be lubricated are lying in the oil or are splash lubricated forced lubrication on request	可供选择的润滑油供油方式; - 浸油润滑 - 采用法兰泵或电动泵进行强制润滑 Possible oil supply variations - Dip lubrication - Forced lubrication by means of flanged on pump or motor pump

3、确定冷却方式 Cooling method	1、如果满足以下条件, 则齿轮箱不需带辅助冷却装置 Adequate for gear units without auxiliary cooling .if; $P_G = P_{GA} \cdot f_4 \cdot f_8 > P_2$
	2、如果满足以下条件, 则齿轮箱带冷却风扇可满足要求 Adequate for gear units with fan cooling .if; $P_G = P_{GB} \cdot f_4 \cdot f_8 > P_2$
	3、如果满足以下条件, 则齿轮箱带冷却盘管可满足要求 Adequate for gear units with cooling coil .if; $P_G = P_{GC} \cdot f_5 \cdot f_8 > P_2$
	4、如果满足以下条件, 则齿轮箱带冷却盘管和风扇可满足要求 Adequate for gear units with cooling coil and fan .if; $P_G = P_{GD} \cdot f_5 \cdot f_8 > P_2$
	5、如果不满足以上条件, 则齿轮箱需带冷却器才能满足要求, 敬请垂询 Adequate for gear units with water-oil cooler for higher thermal capacities on requests

选型指南
计算示例

Guidelines for the selection
Calculation Example

已知:	Known criteria:
原动机	PRIME MOVER
电机功率: $P_1=90kw$	Electric motor: $P_1=90kw$
电机转速: $n_1=1500rpm$	Motor speed: $n_1=1500rpm$
最大起动扭矩: $T_A=850N.m$	Max.starting torque: $T_A=850N.m$
工作机	DRIVER MACHINE
皮带输送机功率: $P_2=82kw$	Belt conveyor: $P_2=82kw$
转速: $n_2=30rpm$	Speed: $n_2=30rpm$
每天运行时间: 12h/日	Duty: 12/day
每小时起动次数: 7	Starts per hurs: 7
每小时工作周期: $E_v=100\%/h$	Operating cycle Perhour: $E_v=100\%/h$
环境温度: $30^\circ C$	Ambient temperature: $30^\circ C$
室内大空间安装: 风速 $\geq 1.4m/s$	Installation in a large hall: wind velocity $\geq 1.4m/s$
海拔高度: 海平面	Altitude: sea level
齿轮箱设计	GEAR UNIT DESIGN
垂直轴齿轮箱	Bevel-helical gear unit
安装方式: 卧式安装	Mounting position: horizontal
输出轴 d_2 : 位于齿轮箱右侧, 布置形式C	Output shaft d_2 : on right hand side design C,
	solid shaft
输出轴 d_2 的旋转方向: 逆时针旋转	Direction of rotation of output shaft d_2 : ccw
中等可靠性要求	

选型步骤

Selecting steps

1. 确定齿轮箱的规格和类型	1. Selection of gear unit and size
1.1 确定传动比 $i_s = \frac{n_1}{n_2} = \frac{1500}{30} = 50$ $i_N = 50$	1.1 Calculation of transmission ratio $i_s = \frac{n_1}{n_2} = \frac{1500}{30} = 50$ $i_N = 50$
1.2 确定齿轮箱额定功率 $P_{2N} \geq P_2 \cdot f_1 \cdot f_2 \cdot S_r = 82 \times 1.3 \times 1 \times 1.4 = 149kw$ 从功率表中选择WV3SH11 对应公称功率: $P_{2N} = 189kw$	1.2 Determination of the gear unit nominal power rating $P_{2N} \geq P_2 \cdot f_1 \cdot f_2 \cdot S_r = 82 \times 1.3 \times 1 \times 1.4 = 149kw$ Selected from power rating rable:type WV3SH11 with : $P_{2N} = 189kw$
1.3校核起动扭矩 $P_{2N} \geq \frac{T_A \times n_1}{9550} \times f_3 = \frac{850 \times 1500}{9550} \times 0.65 = 133.5kw$ $P_{2N} = 189kw > 133.5kw$	1.3Checking the starting torque $P_{2N} \geq \frac{T_A \times n_1}{9550} \times f_3 = \frac{850 \times 1500}{9550} \times 0.65 = 133.5kw$ $P_{2N} = 189kw > 133.5kw$
2. 确定润滑方式 齿轮箱采用浸油润滑	2. Determination of oil supply Gear unit with dip lubrication
3. 确定冷却方式 $P_G = P_{GA} \cdot f_4 \cdot f_8 = 95.8 \times 0.88 \times 1 = 84.3kW > P_2 = 82Kw$ 所以齿轮箱不带辅助冷却装置 最终选定齿轮箱 : WV3SH11-50-C	3. Determination of required trmal capacity $P_G = P_{GA} \cdot f_4 \cdot f_8 = 95.8 \times 0.88 \times 1 = 84.3kW > P_2 = 82Kw$ So auxiliary cooling isn't necessary Type: WV3SH11-50-C



服务系数

Service Factors

表1 工作机系数f1 / Table 1 Factor for driven machine f1									
工作机 Driven machines		I) 日带载运行时间 以小时计算			工作机 Driven machines		I) 日带载运行时间 以小时计算		
		<0.5	>0.5-10	>10			<0.5	>0.5-10	>10
污水处理 Waste water treatment	浓缩器(中心传动) Thickeners(central drive)				输送机 Conveyors				
压滤机 Filter presses		1.0	1.3	1.5	斗式输送机 Bucket conveyors			1.4	1.5
絮凝器 Flocculation apparatus		0.8	1.0	1.3	绞车 Hauling winches			1.4	1.6
曝气机 Aerators			1.8	2.0	卷扬机 Hoists			1.5	1.8
接集设备 Raking equipment		1.0	1.2	1.3	皮带输送机≤150kw Belt conveyors≤150kw	1.0	1.2	1.3	
纵向、回转组合式接集装置 Combined longitudinal and rotary rakes		1.0	1.3	1.5	皮带输送机≥150kw Belt conveyors≥150kw	1.1	1.3	1.4	
预浓缩器 Pre-thickeners			1.1	1.3	货用电梯○ Goods lifts			1.2	1.5
螺杆泵 Screw pumps			1.3	1.5	家用电梯○ Passenger lifts			1.5	1.8
水轮机 Water turbines				2.0	刮板式输送机 Apron conveyors			1.2	1.5
泵 Pumps					自动扶梯 Escalators	1.0	1.2	1.4	
离心泵 Centrifugal pumps		1.0	1.2	1.3	轨道行走机构 Rail travelling gears			1.5	
容积式泵 Positive-displacement pumps					变频装置 Frequency converters			1.8	2.0
1个活塞 1 piston		1.3	1.4	1.8	柱塞式压缩机 Reciprocating compressors			1.8	1.9
>1个活塞 >1 piston		1.2	1.4	1.5	起重机械○○ Cranes				
挖泥机 Dredgers					回转机构○ Slewing gears	1.0	1.4	1.8	
斗式输送机 Bucker conveyors			1.6	1.6	俯仰机构 Luffing gears	1.0	1.1	1.4	
倾卸装置 Dumping devices			1.3	1.5	行走机构 Travelling gears	1.0	1.6	2.0	
履带式行走机构 Caterpillar travelling gears		1.2	1.6	1.8	起升机构 Hoisting gears	1.0	1.1	1.4	
斗轮式挖掘机 Bucket wheel excavators					转臂式起重机 Derricking jib cranes	1.0	1.2	1.6	
用于料堆捡拾 As pick-up			1.7	1.7	冷却塔 Cooling towers				
用于原生岩土 For primitive material			2.2	2.2	冷却塔风扇 Cooling tower fans				2.0
采掘机机头 Cutter heads			2.2	2.2	风机(轴流和离心式) Blower(saxial and redial)			1.4	1.5
采掘臂回转● Traversing gears●			1.4	1.8	食品加工 Food industry				
弯板机● Plate bending machines●			1.0	1.0	蔗糖生产 Cane sugar production				
化学工业 Chemical industry					甘蔗切片机○ Cane knives				1.7
挤出机 Extruders			1.6	1.6	甘蔗碾磨机 Cane mills				1.7
调浆机 Dough mills			1.8	1.8	甜菜糖生产 Beet sugar production				
橡胶抛光机 Rubber calenders			1.5	1.5	甜菜绞碎机 Beet ccosettes macerators				1.2
冷却圆筒 Cooling drums			1.3	1.4	榨取机 Extraction plants				1.4
混匀机, 用于 Mixers for					机械制冷机 Mechanical refrigerators				
均匀介质 Uniform media		1.0	1.3	1.4	蒸煮机 Juice boilers				
非均匀介质 Non-uniform media		1.4	1.6	1.7	甜菜清洗机 Sugar beet washing machines				1.5
搅拌机, 用于 Agitators for media with					甜菜切碎机 Sugar beet cutters				
均匀介质 Uniform density		1.0	1.3	1.5	造纸机械 Paper machines				
不均匀介质 Non-uniform density		1.2	1.4	1.6	各种类型○○○ Of all kind	1.8	2.0		
不均匀气体吸收 Non-uniform gas absorption		1.4	1.6	1.8	碎浆机驱动装置(敬请垂询) Pulper drives(on request)				
烘炉 Toasters		1.0	1.3	1.5	离心式压缩机 Centrifugal compressors	1.4	1.5		
离心机 Centrifuges		1.0	1.2	1.3	索道缆车 Cableways				
金属加工设备 Metal working mills					运货索道 Material ropeways	1.3	1.4		
翻板机 Plate tillers		1.0	1.0	1.2	往复式空中索道 To-and-for system ropeways	1.6	1.8		
推钢机 Ingot pushers		1.0	1.2	1.2	拖牵式索道 T-bar lifts	1.3	1.4		
绕线机 Winding machines			1.6	1.6	循环式索道 Continuous ropeways	1.4	1.6		
冷床横移架 Cooling bed transfer frames			1.5	1.5	水泥工业 Cement industry				
辊式矫直机 Roller straighteners			1.6	1.6	混凝土搅拌机 Concrete mixers	1.5	1.5		
轨道 Roller tables					破碎机 Breakers	1.2	1.4		
连续式 Continuous			1.5	1.5	回转窑 Rotary kilns		2.0		
间歇式 Intermittent			2.0	2.0	管式磨机 Tube mills		2.0		
可逆式轧管机 Reversing tube mills			1.8	1.8	选粉机 Separators	1.6	1.6		
剪切机 Shears					辊压机 Roll crushers		2.0		
连续式● Continuous●			1.5	1.5					
曲柄式● Crank type●			1.0	1.0					
连铸机驱动装置● Continuous casting drivers●			1.4	1.4					
轧机 Rolls									
可逆式开坯机 Reversing blooming mills			2.5	2.5					
可逆式板坯轧机 Reversing slabbing mills			2.5	2.5					
可逆式线材轧机 Reversing wire mills			1.8	1.8					
可逆式薄板轧机 Reversing sheet mills			2.0	2.0					
可逆式中厚板轧机 Reversing plate mills			1.8	1.8					
辊缝调节驱动装置 Roll adjustment mills		0.9	1.0						



服务系数

Service Factors

表2	原动机系数	f2	table 2	Factor for prime mo	f2
电机, 液压马达, 汽轮机		1.0	Electric motors, hydraulic motors turbines		1.0
4-6缸活塞发动机 周期变化1: 100至1: 200		1.25	Piston engines 4-6 cylinders, cyclic variation 1: 100 to 1: 200		1.25
1-3缸活塞发动机 周期变化最高达1: 100		1.5	Piston engines 1-3 cylinders, cyclic variation up to 1: 100		1.5

表3	峰值扭矩系数	f3	table 3	peak torque factor	f3
	每小时峰值荷载次数			load peaks per hour	
	1-5	6-30	31-100	>100	
单向荷载	0.5	0.65	0.7	0.85	
交变荷载	0.7	0.95	1.10	1.25	

表4	环境温度系数 thermal factor									
	(不带辅助冷却装置或仅带冷却风扇进行冷却) (gear units without auxiliary cooling or with fan)									
环境温度/ambient	10℃	15℃	20℃	25℃	30℃	35℃	40℃	45℃	50℃	
f4	1.11	1.06	1.00	0.94	0.88	0.82	0.75	0.69	0.63	

表5	环境温度系数 thermal factor									
	(带冷却盘管或同时带冷却盘管和冷却风扇) (for cooling with cooling coil or with fan and coolincoil)									
环境温度/ambient	10℃	15℃	20℃	25℃	30℃	35℃	40℃	45℃	50℃	
f5	1.05	1.03	1.00	0.97	0.93	0.90	0.87	0.84	0.81	

表8	立式安装齿轮箱供油系数, 对于卧式安装齿轮箱 f8=1.0 当采用强制润滑时 f8=1.05 oil supply factor for vertical gear units, for horizontal gear units f8=1.0 and in case of forced lubrication f8=1.05									
齿轮箱类型 gear unit type	供油方式 oil supply	规格/size 4-12				规格/size 13-18				
		不带辅助冷却装置 without auxiliary cooling	带冷却风扇 with fan	带冷却盘管 with cooling coil	带冷却盘管和冷却风扇 with fan and cooling coil	不带辅助冷却装置 without auxiliary cooling	带冷却风扇 with fan	带冷却盘管 with cooling coil	带冷却盘管和冷却风扇 with fan and cooling coil	
WH2.V WH3.V WH4.V	浸油润滑 dip lubrication	0.95	+	0.95	+	+	+	+	+	
	强制润滑 forced lubricati	1.15	+	1.05	+	1.15	+	1.05	+	
WV2.V WV3.V WV4.V	浸油润滑 dip lubricati	0.95	0.96	0.95	0.95	+	+	+	+	
	强制润滑 forced lubricati	1.15	1.10	1.10	1.10	1.15	1.10	1.10	1.10	

表9	可靠性系数	Sr	table 9	safety factor	st
低可靠性要求		1.2-1.3	low		1.2-1.3
中等可靠性要求		1.3-1.5	normal		1.3-1.5
高可靠性要求		1.5-1.7	high		1.5-1.7

+) 敬请期待

+) On request



公称功率和输出扭矩
类型 WH1
规格 3-19

Nominal Power Rating and Output Torque
Type WH1
Sizes 3-19

公称功率P _{2N} (KW)和公称输出扭矩T _{2N} (KN.m) / Nominal power ratings P _{2N} (kw) and output torque T _{2N} (KN,m)																				
iN	n ₁	n ₂	齿轮箱规格/gear unit sizes (3-19)																	
			3		5		7		9		11		13		15		17		19	
			P _{2N}	T _{2N}	P _{2N}	T _{2N}	P _{2N}	T _{2N}	P _{2N}	T _{2N}	P _{2N}	T _{2N}	P _{2N}	T _{2N}	P _{2N}	T _{2N}	P _{2N}	T _{2N}	P _{2N}	T _{2N}
1.25	1500	1200	382	1055	2004	3258														
	1000	800	254	3.0	704	8.4	1337	16.0	2172	25.9										
	750	600	191		528		1002		1629											
1.4	1500	1071	364	965	1872	3014														
	1000	714	243	3.2	644	8.6	1247	16.7	2009	26.9										
	750	536	182		482		936		1507											
1.6	1500	938	340	886	1680	2794	4744													
	1000	625	226	3.4	590	9.0	1119	17.1	1862	28.4	3161	48.3	4322	66.0						
	750	496	170		443		840		1397		2372		2881							
1.8	1500	833	247	805	1593	2564	4359													
	1000	556	165	2.8	538	9.2	1064	18.3	1712	29.4	2910	50.0	4044	69.5						
	750	417	123		403		796		1282		2179		2696							
2	1500	750	215	723	1369	2208	3779													
	1000	500	143	2.7	482	9.2	912	17.4	1472	28.1	2519	48.1	3740	71.4						
	750	375	107		360		685		1104		1889		2493							
2.24	1500	670	192	660	1223	1973	3478													
	1000	446	127	2.7	439	9.4	814	17.4	1313	28.1	2316	49.5	3441	73.6						
	750	335	96		330		612		986		1739		2294							
2.5	1500	600	178	591	1096	1767	3115	4740												
	1000	400	119	2.8	394	9.4	730	17.4	1178	28.1	2077	49.6	3161	75.5	4655	111.1				
	750	300	89		295		548		883		1558		2370		3103					
2.8	1500	536	170	527	940	1495	2782	4235												
	1000	357	113	3.0	351	9.4	626	16.7	996	26.6	1853	49.6	2820	75.4	4261	113.9				
	750	268	85		264		470		748		1391		2117		2841					
3.15	1500	476	151	468	850	1372	2349	3570												
	1000	317	100	3.0	312	9.4	565	17.0	913	27.5	1564	47.1	2377	71.5	3910	117.6				
	750	238	75		234		425		686		1175		1785		2607					
3.55	1500	423	138	412	772	1241	2179	3229												
	1000	282	92	3.1	274	9.3	515	17.4	827	28.0	1452	49.2	2152	73.0	3534	119.8				
	750	211	69		206		386		620		1089		1615		2356					
4	1500	375	119	357	663	1070	1887	2823												
	1000	250	79	3.0	238	9.1	442	16.9	713	27.3	1258	48.0	1882	71.9	3233	123.5	4302	164.3		
	750	188	59		179		332		535		943		1412		2155		2868			
4.5	1500	333	83	255	523	814	1523	2040	3610											
	1000	222	55	2.4	169	7.3	349	15.0	542	23.3	1016	43.6	1359	58.4	2406	103.4	3233	138.5		
	750	167	41		127		261		407		761		1020		1805		2149			
5	1500	300	71	215	411	701	1154	1739	2835	3700										
	1000	200	48	2.3	143	6.8	275	13.1	467	22.3	770	36.7	1159	55.3	1890	90.2	2466	117.5	3461	
	750	150	36		107		206		351		577		870		1417		1850		2307	
5.6	1500	268	61	183	349	536	973	1476	2409	3145	3999									
	1000	179	41	2.2	123	6.6	233	12.4	357	19.1	650	34.8	986	52.7	1609	86.1	2100	112.3	2670	
	750	134	30		92		174		268		750		738		1205		1573		1999	

采取强制润滑

Forced lubrication required



热功率
类型 WH1
规格 3-11

Thermal Capacities
Type WH1
Sizes 3-11

热功率PG(kw) / Thermal capacities PG(kw)																		
iN	n ₁	n ₂	齿轮箱规格 / Gear unit sizes 3-11															
			3			5			7			9			11			
			P _G	T _G	T _G	P _G	T _G	T _G	P _G	T _G	T _G	P _G	T _G	T _G	P _G	T _G	T _G	
1.25	PGA	68	63.2	*	*	*	*	*	*	*	*	*	*	*	*	*	*	*
	PGB	157	187	210	338	402	372	427	517	408	443	536	*					
	PGD	234	271	307	553	639	686	798	911	946	1128	1276						
1.4	PGA	70	65.4	*	*	*	*	*	*	*	*	*	*	*	*	*	*	*
	PGB	156	186	212	344	409	392	441	534	447	477	578	375					
	PGD	228	264	299	544	629	680	781	892	937	1119	1277	1285					
1.6	PGA	73	68.6	*	*	*	*	*	*	*	*	*	*	*	*	*	*	*
	PGB	154	183	213	346	412	420	446	540	520	630	495	602	729	*			
	PGD	215	248	284	515	595	655	730	833	894	1077	1230	1276	1802	2057	1944		
1.8	PGA	85	79.9	*	*	*	*	*	*	*	*	*	*	*	*	*	*	*
	PGB	172	205	241	344	410	435	463	561	554	654	541	655	575	678	821	*	
	PGD	233	269	309	485	561	625	717	819	894	1040	1187	1259	1774	2025	1990		
2	PGA	84	78.5	*	111	104	*	*	*	*	*	*	*	*	*	*	*	*
	PGB	165	197	234	333	397	427	453	549	553	658	651	590	704	852	509		
	PGD	221	256	295	459	531	593	682	778	852	990	1130	1207	1713	1955	1947		
2.24	PGA	74	78	*	104	109	*	*	*	*	*	*	*	*	*	*	*	*
	PGB	159	189	227	321	382	422	430	520	544	653	645	620	733	887	631		
	PGD	208	241	278	429	496	558	617	704	779	931	1063	1151	1633	1864	1902		
2.5	PGA	69	72.8	*	103	108	*	*	*	*	*	*	*	*	*	*	*	*
	PGB	147	175	211	304	362	405	408	494	525	613	621	614	730	884	676		
	PGD	187	216	251	397	459	518	569	649	723	864	986	1075	1536	1753	1810		
2.8	PGA	66	69.6	50	100	105	*	138	133	*	*	*	*	*	*	*	*	*
	PGB	138	164	199	286	340	384	422	511	553	649	658	714	865	705			
	PGD	172	199	231	362	419	475	574	655	733	871	994	1091	1424	1625	1698		
3.15	PGA	70	73	63.8	121	127	*	196	189	*	226	217	*	*	*	*	*	*
	PGB	135	161	200	292	348	415	496	601	702	604	731	828	842	1019	1055		
	PGD	167	193	226	360	416	481	674	769	881	956	1091	1237	1473	1682	1858		
3.55	PGA	64	67.6	59.8	121	127	*	185	178	*	217	209	*	*	*	*	*	*
	PGB	123	147	183	286	340	407	457	553	649	563	682	778	784	949	998		
	PGD	151	174	204	344													



热功率
类型 WH1
规格13-19

Thermal Capacities
Type WH1
Sizes 13-19

热功率PG(kw)/ Thermal capacities PG(kw)													
in	n1	齿轮箱规格 / Gear unit sizes 13-19											
		13			15			17			19		
		750	1000	1500	750	1000	1500	750	1000	1500	750	1000	1500
1.25	PGA												
	PGB												
	PGC												
	PGD												
1.4	PGA												
	PGB												
	PGC												
	PGD												
1.6	PGA	*	*	*									
	PGB	431	510	*									
	PGC	2154	2459	2060									
	PGD	2733	3313	3187									
1.8	PGA	*	*	*									
	PGB	570	674	*									
	PGC	2117	2417	2161									
	PGD	2693	3264	3328									
2	PGA	*	*	*	*	*	*	*	*	*	*	*	*
	PGB	640	757	*	*	*	*	*	*	*	*	*	*
	PGC	2074	2368	2161	1870	2073	1626	*	*	*	*	*	*
	PGD	2632	3190	3313	2571	3116	2826	*	*	*	*	*	*
2.24	PGA	*	*	*	*	*	*	*	*	*	*	*	*
	PGB	720	851	*	442	523	*	*	*	*	*	*	*
	PGC	2006	2290	2172	1847	2048	1719	*	*	*	*	*	*
	PGD	2561	3104	3336	2535	3073	2963	*	*	*	*	*	*
2.5	PGA	*	*	*	*	*	*	*	*	*	*	*	*
	PGB	751	888	*	525	621	*	*	*	*	*	*	*
	PGC	1904	2174	2102	1818	2016	1746	*	*	*	*	*	*
	PGD	2438	2955	3228	2472	2996	2972	*	*	*	*	*	*
2.8	PGA	*	*	*	*	*	*	*	*	*	*	*	*
	PGB	763	902	*	598	707	*	423	500	*	*	*	*
	PGC	1782	2034	2002	1765	1957	1748	2009	2203	1836	*	*	*
	PGD	2285	2770	3075	2386	2892	2947	2659	3223	3087	*	*	*
3.15	PGA	*	*	*	*	*	*	*	*	*	*	*	*
	PGB	954	1128	1033	970	1146	816	880	1040	*	*	*	*
	PGC	1818	2075	2221	1965	2179	2223	2295	2517	2487	*	*	*
	PGD	2346	2844	3394	2619	3174	3634	2990	3624	4035	*	*	*
3.55	PGA	*	*	*	*	*	*	*	*	*	*	*	*
	PGB	912	1078	1014	964	1140	860	927	1096	678	*	*	*
	PGC	1661	1898	2042	1828	2027	2087	2176	2387	2387	*	*	*
	PGD	2147	2603	3123	2427	2942	3397	2815	3412	3839	*	*	*
4	PGA	*	*	*	*	*	*	*	*	*	*	*	*
	PGB	866	1024	1012	951	1124	938	958	1132	821	873	1032	623
	PGC	1502	1715	1870	1670	1851	1943	2017	2212	2263	*	*	*
	PGD	1950	2364	2866	2221	2692	3159	2605	3158	3625	*	*	*
4.5	PGA	345	304	*	*	*	*	*	*	*	*	*	*
	PGB	937	1107	1193	1090	1289	1261	1106	1307	1192	1078	1274	1069
	PGC	1562	1783	1992	1721	1908	2075	2031	2227	2382	*	*	*
	PGD	2041	2474	3062	2277	2760	3339	2615	3170	3779	*	*	*
5	PGA	386	340	*	*	*	*	*	*	*	*	*	*
	PGB	920	1087	1227	1114	1317	1395	1304	1541	1560	1341	1585	1526
	PGC	1477	1686	1911	1642	1820	2022	2210	2424	2660	*	*	*
	PGD	1937	2348	2942	2180	2642	3255	2844	3447	4202	*	*	*
5.6	PGA	353	311	*	*	*	*	*	*	*	*	*	*
	PGB	827	978	1104	1011	1195	1266	1198	1416	1433	1409	1665	1604
	PGC	1295	1478	1675	1450	1608	1787	1967	2157	2367	*	*	*
	PGD	1704	2065	2586	1929	2338	2880	2532	3069	3741	*	*	*

* 敬请期待
PGA(KW) 齿轮箱不带辅助冷却措施
PGB(KW) 齿轮箱带冷却风扇
PGC(KW) 齿轮箱带内置冷却盘管
PGD(KW) 齿轮箱带冷却风扇和内置冷却盘管

* On request
PGA(KW) Gear units without auxiliary cooling
PGB(KW) Gear units with fan
PGC(KW) Gear units with built-in cooling coil
PGD(KW) Gear units with fan and built-in cooling coil



公称功率和输出扭矩
类型 WH2
规格 4-15

Nominal Power Rating and Output Torque
Type WH2
Sizes 4-15

公称功率P2N(KW)和公称输出扭矩T2N(KN.m)/Nominal power ratings P2N(kw) and output torque T2N(KN.m)																										
in	n1	n2	齿轮箱规格/gear unit sizes (4-15)																							
			4		5		6		7		8		9		10		11		12		13		14		15	
			P2N	T2N	P2N	T2N	P2N	T2N	P2N	T2N	P2N	T2N	P2N	T2N	P2N	T2N	P2N	T2N	P2N	T2N	P2N	T2N	P2N	T2N	P2N	T2N
6.3	1500	238	165		279				530				881				1551				2250				3741	
	1000	159	109	6.6	187	11.2			354	21.3			589	35.4			1036	62.4			1503	90.4			2499	150
	750	119	82		140				265				442				777				1127				1874	
7.1	1500	211	150		259				470				781				1376				1995				3317	
	1000	141	100	6.8	173	11.7			314	21.3			522	35.4			919	62.3			1332	90.3			2217	150
	750	106	75		130				235				391				689				999				1662	
8	1500	188	138		231				278				419				528				696				872	
	1000	125	91	7.0	153	11.7			185	14.1			278	21.3			352	26.9			463	35.4			580	
	750	94	69		115				139				209				264				347				435	
9	1500	167	123		205				264				372				469				618				774	
	1000	111	81	6.9	137	11.7			175	15.1			247	21.2			312	26.8			411	35.3			515	
	750	83	61		102				132				185				234				308				386	
10	1500	150	96		161				237				312				422				518				695	
	1000	100	64	6.1	107	10.2			158	15.0			208	19.8			281	26.9			345	32.9			463	
	750	75	48		80				118				156				211				259				347	
11.2	1500	134	86		145				212				278				377				463				622	
	1000	89	57	6.1	96	10.3			141	15.0			185	19.8			250	26.7			308	32.9			413	
	750	67	43		72				106				139				187				231				309	
12.5	1500	120	82		137				166				248				315				415				519	
	1000	80	55	6.6	91	10.9			111	13.2			166	19.8			210	25.0			276	33.0			346	
	750	60	41		68				83				124				157				207				259	
14	1500	107	74		123				148				222				280				369				463	
	1000	71	48	6.4	81	10.9			98	13.1			147	19.7			186	24.9			245	32.8			307	
	750	54	36		61				74				110				140				184				230	
16	1500	94	64		108				138				195				245				324				407	
	1000	63	43	6.6	72	10.9			92	14.1			130	19.9			165	25.2			218	33.2			272	
	750	47	32		54				69				98				123				163				204	
18	1500	83	53		89				123				162				218				286				359	
	1000	56	35	6.1	60	10.3			82	14.2			109	18.7			147	25.3			193	33.2			242	
	750	42	26		45				62				82				110				145				182	
20	1500	75	48		83				111				142				197				251				324	
	1000	50	32	6.2	55	10.5			74	14.0			94	18.0			131	25.1			167	31.9			216	
	750	38	24		41				55				71				98				125				162	
22.4	1500	67	42		72				92				131				165				220				290	
	1000	45	28	5.9	48	10.4			62	13.2			88	18.9			111	23.7			147	31.5			194	
	750	33	21		36				46				66				83				110				146	
25	1500	60							85								143				252				340	
	1000	40							56	13.4							95	22.7			167	39.9			294	
	750	30							42								71				125				220	
28	1																									



公称功率和输出扭矩
类型 WH2
规格 16-26

Nominal Power Rating and Output Torque
Type WH2
Sizes 16-26

公称功率P _{2N} (KW)和公称输出扭矩T _{2N} (KN.m)/Nominal power ratings P _{2N} (kw) and output torque T _{2N} (KN,m)																										
in	n ₁	n ₂	齿轮箱规格/gear unit sizes (16-26)																							
			16		17		18		19		20		21		22		23		24		25		26			
			P _{2N}	T _{2N}	P _{2N}	T _{2N}	P _{2N}	T _{2N}	P _{2N}	T _{2N}	P _{2N}	T _{2N}	P _{2N}	T _{2N}	P _{2N}	T _{2N}	P _{2N}	T _{2N}	P _{2N}	T _{2N}	P _{2N}	T _{2N}	P _{2N}	T _{2N}		
6.3	1500	238			5102																					
					3408	205			5104																	
					2556				3828	307																
7.1	1500	211	3712		4523																					
					3023	205	3565		4527		5193															
					2267		2674	242	3395		3895	352														
8	1500	188	3306		4030		4753																			
					2680	205	3161	241	4012		4603															
					2010		2370		3009		3452	352														
9	1500	167	2937		3579		4222																			
					2379	205	2807	241	3563	306	4088	351	4670	401												
					1784		2105		2672		3066		3502													
10	1500	150	2639		3001		3793		4494																	
					2000	191	2528	241	2996	286	3682	352	4207	402	4699	449										
					1500		1896		2247		2762		3155		3524											
11.2	1500	134	2200		2681		3162		4015		4606															
					1781	190	2100	225	2667	285	3059	327	3744	400	4183	447										
					1335		1575		2000		2294		2808		3137											
12.5	1500	120	1970		2401		2832		3596		4125															
					1600	191	1887	225	2397	286	2750	328	3365	402	3759	449	4433	529								
					1200		1416		1798		2062		2524		2819		3324									
14	1500	107	1756		2140		2524		3107		3678		4501													
					1420	190	1675	224	2062	276	2440	326	2987	399	3337	446	3934	526	4517	604						
					1065		1256		1546		1830		2240		2503		2950		3388							
16	1500	94	1543		1881		2218		2730		3132		3833		4418											
					1260	193	1487	227	1830	280	2099	321	2569	393	2961	452	3491	533	4008	612						
					945		1115		1372		1574		1927		2220		2618		3006							
18	1500	83	1362		1660		1958		2410		2765		3385		3781		4458									
					1120	193	1321	227	1626	280	1886	321	2284	393	2551	438	3008	517	3562	612	4344	747				
					840		991		1220		1399		1713		1913		2256		2672		3258					
20	1500	75	1231		1454		1770		2178		2499		3058		3416		4028		4626							
					969	185	1180	225	1452	277	1665	318	2039	389	2277	435	2686	513	3084	589	3879	741	4377	836		
					727		885		1089		1249		1529		1708		2014		2313		2909		3282			
22.4	1500	67	1056				1532				2233				3052				4132							
							1029	220			1499	321			2050	439			2775	594		3939	843			
							772				1124				1538				2081			2954				
25	1500	60																								
28	1500	54																								

采取强制润滑

Forced lubrication required



热功率
类型 WH2
规格 4-9

Thermal Capacities
Type WH2
Sizes 4-9

热功率PG(kw)/Thermal capacities PG(kw)																						
in	n ₁	n ₂	齿轮箱规格/Gear unit sizes(4-9)																			
			4			5			6			7			8			9				
			750	1000	1500	750	1000	1500	750	1000	1500	750	1000	1500	750	1000	1500	750	1000	1500		
6.3	PGA	PGB	PGC	PGD	52.8	54.1	48.5	64.9	66.5	48.8				99	90.3	*			128	116	*	
					88.8	106	132	120	143	172				183	221	256				242	293	322
					103.8	120	146	164	190	226				267	305	357				416	475	542
					134	162	210	212	256	327				341	417	525				511	626	774
7.1	PGA	PGB	PGC	PGD	54.7	56.1	51.6	67.3	69	53.9				99	89.8	*			129	117	*	
					91.3	109	137	122	146	177				177	214	252				236	286	323
					105	121	148	164	189	226				237	287	338				369	447	516
					137	165	214	212	256	327				322	394	499				481	589	735
8	PGA	PGB	PGC	PGD	53.1	54.4	51.4	66.7	68.3	56.4	72.7	74.5	59.2	98	89.1	64.9	109	99	*	130	118	*
					87.1	104	132	119	142	175	132	157	191	172	208	249	194	235	276	230	279	322
					99.5	115	140	158	182	219	170	197	236	238	272	323	273	312	367	372	425	496
					128	155	202	203	245	316	220	266	341	307	376	479	350	428	542	459	562	707
9	PGA	PGB	PGC	PGD	52.1	53.4	52.4	66.3	67.9	60.5	76.2	78.1	67.8	98	89.3	73.2	110	100	77.2	132	120	86.3
					84.6	101	129	116	139	174	133	159	198	167	202	248	188	228	275	225	272	324
					94.2	109	135	151	174	211	170	197	238	227	259	311	258	294	352	353	403	477
					124	150	196	194	234	303	220	266	344	292	357	458	331	405	518	438	526	682
10	PGA	PGB	PGC	PGD	47.1	51.1	51.4	60.3	65.4	61.1	71.4	77.4	70.9	86	88.3	77.7	98	100	84.2	116	119	96
					80.2	95.7	123	110	131	165	131	156	196	159	193	241	183	222	273	216	262	320
					88.3	102	126	138	160	196	164	189	230	213	243	295	245	280	338	331	378	453
					115	139	182	180	217	282	211	255	331	275	337	436	315	386	498	412	505	648
11.2	PGA	PGB	PGC	PGD	45.5	49.3	50.4	58.5	63.4	61.2	70.1	76	72.2	89	90.7	83.4	97	99	88	113	116	99.9
					76.8	91.7	118	106	126	160	127	151	191	162	196	246	177	214	267	206	249	309
					83.9	97	120	131	151	185	156	180	221	211	241	294	231	264	321	309	353	427
					109	132	174	170	205	268	203	245	319	274	336	436	300	367	475	386	473	610
12.5	PGA	PGB	PGC	PGD	44.1	47.8	49.5	58.1	63	62.1	66.7	72.3	70.5	88	90.2	85.6	93	95.6	88.3	113	116	104
					73.4	87.6	113	103	123	157	119	142	181	158	191	242	169	205	258	202	244	305
					81	93.6	116	129	149	183	143	165	204	207	236	289	219	250	305	300	342	415
					104	126	166	166	201	263	187	226	295	267	327	425	283	346	450	372	455	589
14	PGA	PGB	PGC	PGD	42.0	45.5	47.6	55.3	60	60.4	64.4	69.8	69.5	82	83.8	81.7	95	97.7	93.2	111	114	106
					69.5	82.9	108	97.2	116	150	113	135	174	145	175	224	171	207	263	195	23	



热功率
类型 WH3
规格5-10

Thermal Capacities
Type WH3
Sizes 5-10

in		热功率PG(kw)/ Thermal capacities PG(kw)																	
		齿轮箱规格/Gear unit sizes(5-10)																	
		5			6			7			8			9			10		
n1	750	1000	1500	750	1000	1500	750	1000	1500	750	1000	1500	750	1000	1500	750	1000	1500	
22.4	PGA																		
	PGB																		
	PGC																		
	PGD																		
25	PGA	46.0	49.9	52.5						68.5	73.5	76.1				92.6	99.3	100	
	PGB	62.1	73.4	92.4						90.9	110	138				126	152	187	
	PGC	91.1	105	130						147	169	208				214	247	302	
	PGD	103	125	163						164	201	261				239	293	378	
28	PGA	44.3	48	50.9						69.2	74.2	77.5				92.3	99	101	
	PGB	59.8	70.7	89.4						92.5	112	140				124	150	186	
	PGC	86.5	99.7	123						145	167	207				207	239	294	
	PGD	97.7	118	155						163	200	261				232	284	368	
31.5	PGA	43.1	46.7	49.9	49.8	54	57.4	66.6	71.4	75.3	73.8	79.1	82.8	90.4	96.9	100	93.3	100	102
	PGB	57.9	68.5	86.9	66.5	78.6	99.6	88.4	107	135	97.5	118	148	121	146	183	125	151	188
	PGC	83.0	95.6	118	94.6	109	135	137	158	195	150	173	214	200	230	283	248	286	352
	PGD	94.3	114	149	108	130	170	155	190	248	168	206	868	223	273	355	272	333	432
35.5	PGA	41.7	45.2	48.6	47.9	51.9	55.7	64.7	69.4	73.9	74.3	79.7	84.4	87.6	93.9	98.7	93.1	99.8	104
	PGB	56.0	66.2	84.3	63.9	75.6	96.2	85.0	104	132	98.3	119	150	117	142	178	123	149	186
	PGC	79.2	91.3	113	89.4	103	127	131	151	188	148	171	211	190	219	271	241	278	343
	PGD	90.2	109	143	102	123	161	149	183	239	167	205	268	214	262	342	264.6	324	421
40	PGA	39.4	42.7	46.1	46.5	50.4	54.3	61.6	66	70.6	71.4	76.6	81.4	82.9	88.9	93.9	90	96.5	101
	PGB	52.7	62.3	79.5	62.0	73.3	93.4	81.7	98.9	125	98.1	113	144	111	134	170	120	145	182
	PGC	73.6	84.8	105	85.8	98.8	122	122	141	175	140	161	200	177	204	252	230	265	327
	PGD	83.6	101	133	96.8	117	154	139	170	223	158	194	254	199	244	319	253	310	404
45	PGA	37.6	40.8	44.2	44.9	48.7	52.5	59.3	63.6	68.2	69.3	74.3	79.2	79.8	85.6	90.8	87.7	94	99.1
	PGB	50.4	59.6	76.1	59.8	70.7	90.2	78.5	95	120	90.9	110	140	106	128	162	116	141	177
	PGC	69.5	80.1	99.7	81.9	94.4	117	116	134	167	135	155	192	168	193	239	220	254	314
	PGD	79.4	96	126	93.5	113	148	132	162	212	152	186	243	189	232	303	243	298	388
50	PGA	36.5	39.6	43.2	42.5	46.1	50.1	56.0	60.1	65.2	66.1	70.9	76.6	78.5	84.2	90.6	83.4	89.4	95.9
	PGB	48.6	57.5	73.8	56.4	66.7	85.5	74.0	89.6	114	85.9	104	133	104	126	160	110	133	169
	PGC	67.1	77.3	96.4	76.1	87.7	109	109	126	157	126	145	181	164	189	235	205	236	293
	PGD	76.8	92.8	122	86.9	105	138	124	152	200	142	174	228	184	225	295	226	277	362
56	PGA	34.7	37.6	41.2	40.9	44.3	48.5	53.6	57.2	62.7	63.8	68.4	74.4	75.0	80.4	87.3	80.4	86.2	93.4
	PGB	46.1	54.5	70.1	54.0	63.9	82.2	70.4	85.2	109	82.6	100	129	99.1	120	153	106	128	154
	PGC	63.0	72.6	90.6	72.0	83	103	102	118	148	120	138	172	153	176	219	194	223	278
	PGD	71.8	86.7	114	82.5	99.7	131	117	143	188	136	166	218	173	212	278	214	262	344
63	PGA	32.7	35.5	39.1	39.4	42.7	47	50.1	53.7	59	60.3	64.7	71	71.1	76.2	83.5	78.9	84.6	92.5
	PGB	43.3	51.2	66.1	51.9	61.4	79.2	65.6	79.4	102	78.6	95.1	122	92.5	112	145	102	124	160
	PGC	58.4	67.3	84.1	69.5	80.1	100	94.6	109	136	112	129	161	141	163	204	189	218	272
	PGD	66.7	80.6	106	79.6	96.2	126	106	130	172	127	156	205	161	197	259	210	257	338
71	PGA	32.4	35.1	38.7	37.4	40.5	44.6	48.6	52.1	57.3	57.4	61.6	67.7	69.6	74.6	81.8	75.1	80.5	88.2
	PGB	42.8	50.6	65.3	49.1	58.1	75	63.4	76.7	98.9	74.7	90.4	116	90.9	110	142	98.3	119	153
	PGC	57.7	66.5	83.1	65.2	75.1	93.8	80.3	104	130	104	120	151	139	160	200	177	204	255
	PGD	66.0	79.7	105	74.4	89.9	118	103	126	166	118	145	192	156	191	252	195	239	315
80	PGA	30.7	33.3	36.8	35.2	38.2	42.1	47.5	50.9	56	53.7	57.6	63.3	65.8	70.6	77.6	71.0	76.1	83.5
	PGB	40.5	47.9	61.9	46.1	54.5	70.3	61.9	74.9	96.6	69.5	84.1	108	85.9	104	134	91.7	111	143
	PGC	53.6	61.6	77.3	60.5	69.7	87.3	86.8	100	125	96.3	111	137	128	148	185	164	189	236
	PGD	61.4	74.2	97.9	69.2	83.6	110	98.8	121	160	109	134	177	146	179	236	181	222	293
90	PGA	30.3	32.9	36.3	34.9	37.8	41.8	44.9	48.1	53.1	51.9	55.7	61.4	62.6	67.1	73.8	69.3	74.3	81.6
	PGB	40.0	47.3	61.1	45.7	54.1	69.8	58.4	70.7	91.3	67.0	81.1	104	81.6	98.9	127	89.2	108	140
	PGC	52.2	60.1	75.1	60.0	69.1	86.4	80.8	93.1	116	92.9	107	133	120	138	172	161	185	231
	PGD	59.8	72.3	95.5	68.5	82.8	109	91.5	112	148	105	129	171	136	166	219	177	217	286
100	PGA				33.1	35.9	39.7				50.9	54.6	60.4				65.9	70.7	78
	PGB				43.3	51.2	66.2				65.7	79.1	102				85.1	103	133
	PGC				55.7	64.2	80.3				89.4	103	129				149	172	215
	PGD				63.9	77.2	101				102	125	165				165	202	266
112	PGA				32.7	35.5	39.3				48.2	51.7	57.2				62.7	67.2	74.3
	PGB				42.9	50.7	65.6				62.1	75.2	97.3				81.2	98.3	127
	PGC				54.2	62.5	78.3				83.1	95.6	119				138	159	199
	PGD				62.2	75.2	99.4				94.7	116	153				154	188	248

* 敬请期待
PGA(KW) 齿轮箱不带辅助冷却措施
PGB(KW) 齿轮箱带冷却风扇
PGC(KW) 齿轮箱带内置冷却盘管
PGD(KW) 齿轮箱带冷却风扇和内置冷却盘管

* On request
PGA(KW) Gear units without auxiliary cooling
PGB(KW) Gear units with fan
PGC(KW) Gear units with built-in cooling coil
PGD(KW) Gear units with fan and built-in cooling coil



热功率
类型 WH3
规格11-16

Thermal Capacities
Type WH3
Sizes 11-16

in		热功率PG(kw)/ Thermal capacities PG(kw)																	
		齿轮箱规格/Gear unit sizes(11-16)																	
		11			12			13			14			15			16		
n1	750	1000	1500	750	1000	1500	750	1000	1500	750	1000	1500	750	1000	1500	750	1000	1500	
22.4	PGA																		
	PGB																		
	PGC																		
	PGD																		
25	PGA	135	145	138															
	PGB	190	230	275															
	PGC	364	419	507															
	PGD	402	492	626															
28	PGA	132	142	137															
	PGB	183	222	268															
	PGC	340	392	477															
	PGD	379	464	593															
31.5	PGA	129	138	137	153	164	159	178	184	173	204	211	196	243	252	217	256	265	222
	PGB	178	215	263	211	255	308	236	279	332	270	319	377	348	411	468	366	432	487
	PGC	325	374	457	374	431	523	417	480	580	483	556	670	680	783	930	720	829	981
	PGD	362	443	570	416	509	650	462	560	710	534	647	819	757	917	1143	799	969	1202
35.5	PGA	125	134	135	148	159	158	174	180	175	199	206	198	235</					



热功率
类型 WH3
规格17-22

Thermal Capacities
Type WH3
Sizes 17-22

热功率PG(kw)/Thermal capacities PG(kw)																			
齿轮箱规格/Gear unit sizes(17-22)																			
in	n ₁	17			18			19			20			21			22		
		750	1000	1500	750	1000	1500	750	1000	1500	750	1000	1500	750	1000	1500	750	1000	1500
22.4	PGA	261	270	180				317	325	*				342	350	*			
	PGB	372	440	450				*	*	*				*	*	*			
	PGC	784	903	1035				*	*	*				*	*	*			
	PGD	849	1029	1228				*	*	*				*	*	*			
25	PGA	254	263	180	266	276	*	315	232	*	325	333	*	354	363	*	335	343	*
	PGB	361	427	442	382	451	455	*	*	*	*	*	*	*	*	*	*	*	*
	PGC	739	851	979	786	906	1035	*	*	*	*	*	*	*	*	*	*	*	*
	PGD	802	972	1164	852	1033	1227	*	*	*	*	*	*	*	*	*	*	*	*
28	PGA	256	265	198	264	274	196	318	326	222	330	338	*	371	380	*	361	370	*
	PGB	360	425	455	373	441	464	*	*	*	*	*	*	*	*	*	*	*	*
	PGC	711	819	953	741	854	988	*	*	*	*	*	*	*	*	*	*	*	*
	PGD	777	942	1145	809	981	1182	*	*	*	*	*	*	*	*	*	*	*	*
31.5	PGA	254	263	212	266	276	216	319	327	246	333	341	249	385	394	*	380	389	*
	PGB	354	418	463	372	440	480	*	*	*	*	*	*	*	*	*	*	*	*
	PGC	681	785	924	717	826	967	*	*	*	*	*	*	*	*	*	*	*	*
	PGD	747	906	1116	785	952	1165	*	*	*	*	*	*	*	*	*	*	*	*
35.5	PGA	246	255	221	264	274	232	317	325	268	334	342	276	394	404	273	394	404	*
	PGB	339	401	459	366	433	489	*	*	*	*	*	*	*	*	*	*	*	*
	PGC	629	725	863	685	789	935	*	*	*	*	*	*	*	*	*	*	*	*
	PGD	696	844	1052	756	916	1137	*	*	*	*	*	*	*	*	*	*	*	*
40	PGA	238	247	221	255	264	231	309	317	372	328	336	283	391	401	293	397	407	269
	PGB	327	387	449	349	412	474	*	*	*	*	*	*	*	*	*	*	*	*
	PGC	595	685	820	634	730	871	*	*	*	*	*	*	*	*	*	*	*	*
	PGD	659	799	1003	704	853	1066	*	*	*	*	*	*	*	*	*	*	*	*
45	PGA	237	246	224	245	254	227	308	316	276	318	326	280	384	393	297	392	402	278
	PGB	324	383	448	336	397	460	*	*	*	*	*	*	*	*	*	*	*	*
	PGC	582	670	804	598	689	823	*	*	*	*	*	*	*	*	*	*	*	*
	PGD	645	782	985	663	804	1009	*	*	*	*	*	*	*	*	*	*	*	*
50	PGA	239	248	242	250	259	250	312	320	304	324	332	313	400	410	360	400	410	344
	PGB	322	381	462	338	399	480	*	*	*	*	*	*	*	*	*	*	*	*
	PGC	568	655	797	582	671	815	*	*	*	*	*	*	*	*	*	*	*	*
	PGD	636	771	987	654	793	1012	*	*	*	*	*	*	*	*	*	*	*	*
56	PGA	232	240	243	249	258	260	304	311	310	324	332	329	391	401	379	411	421	387
	PGB	311	367	453	333	394	485	*	*	*	*	*	*	*	*	*	*	*	*
	PGC	533	614	752	573	660	808	*	*	*	*	*	*	*	*	*	*	*	*
	PGD	596	723	934	641	777	1001	*	*	*	*	*	*	*	*	*	*	*	*
63	PGA	222	230	241	241	250	262	288	295	307	316	324	336	384	393	397	403	413	411
	PGB	295	349	439	320	378	474	*	*	*	*	*	*	*	*	*	*	*	*
	PGC	492	567	700	535	616	760	*	*	*	*	*	*	*	*	*	*	*	*
	PGD	554	672	876	602	730	950	*	*	*	*	*	*	*	*	*	*	*	*
71	PGA	213	221	234	229	237	249	285	292	306	296	303	316	364	373	381	388	397	400
	PGB	283	334	422	302	357	450	*	*	*	*	*	*	*	*	*	*	*	*
	PGC	470	542	671	496	571	706	*	*	*	*	*	*	*	*	*	*	*	*
	PGD	531	644	841	558	676	881	*	*	*	*	*	*	*	*	*	*	*	*
80	PGA	206	213	227	220	228	241	270	277	292	292	299	315	349	358	369	368	377	384
	PGB	272	321	406	290	343	433	*	*	*	*	*	*	*	*	*	*	*	*
	PGC	444	512	635	474	546	676	*	*	*	*	*	*	*	*	*	*	*	*
	PGD	502	608	795	535	648	846	*	*	*	*	*	*	*	*	*	*	*	*
90	PGA	194	201	215	211	219	233	257	263	280	276	283	300	341	349	363	352	361	372
	PGB	256	302	384	278	329	417	*	*	*	*	*	*	*	*	*	*	*	*
	PGC	411	474	588	448	516	640	*	*	*	*	*	*	*	*	*	*	*	*
	PGD	465	564	738	507	614	803	*	*	*	*	*	*	*	*	*	*	*	*
100	PGA				201	208	226				266	272	294				348	356	379
	PGB				262	310	397				*	*	*				*	*	*
	PGC				415	478	595				*	*	*				*	*	*
	PGD				469	569	748				*	*	*				*	*	*
112	PGA																		
	PGB																		
	PGC																		
	PGD																		

* 敬请期待
PGA(KW) 齿轮箱不带辅助冷却措施
PGB(KW) 齿轮箱带冷却风扇
PGC(KW) 齿轮箱带内置冷却盘管
PGD(KW) 齿轮箱带冷却风扇和内置冷却盘管

* On request
PGA(KW) Gear units without auxiliary cooling
PGB(KW) Gear units with fan
PGC(KW) Gear units with built-in cooling coil
PGD(KW) Gear units with fan and built-in cooling coil



公称功率和输出扭矩
类型 WH4
规格 7-16

Nominal Power Rating and Output Torque
Type WH4
Sizes 7-16

公称功率P _{2N} (KW)和公称输出扭矩T _{2N} (KN.m)/Nominal power ratings P _{2N} (kw) and output torque T _{2N} (KN,m)																						
齿轮箱规格/gear unit sizes (7-16)																						
in	n ₁	n ₂	7		8		9		10		11		12		13		14		15		16	
			P _{2N}	T _{2N}	P _{2N}	T _{2N}	P _{2N}	T _{2N}	P _{2N}	T _{2N}	P _{2N}	T _{2N}	P _{2N}	T _{2N}	P _{2N}	T _{2N}	P _{2N}	T _{2N}	P _{2N}	T _{2N}	P _{2N}	T _{2N}
100	1500	15	35.7				59				101				149				252			
	1000	10	23.1	22.1			39	37.1			67	64.2			99	94.3			168	160		
	750	7.5	17.3				29				50				74				126			
112	1500	13.4	31.5				53				90				133				225		254	
	1000	8.9	21	22.5			35	37.1			60	64.0			88	94.3			149	159	169	181
	750	6.7	15.8				26				45				66				112		127	
125	1500	12	28.4				36	46		58	81		103		119		148		202		228	
	1000	8	18.9	22.6	23	27.6	30	36.3	39	46.4	54	63.9	68	81.5	79	94.0	99	118	134	160	151	180
	750	6	14.2				17	23			29	40			51	59			74	101		113
140	1500	10.7	25.2				32	41		51	72		91		106		132		180		203	
	1000	7.1	16.8	22.5	21	28.1	27	36.5	34	44.9	47	63.2	60	80.0	70	94.1	88	118	119	159	134	180
	750	5.4	12.6				16	20			25	35			45	53			66	89		101
160	1500	9.4	22.1				27	37		45	63		80		93		117		158		179	
	1000	6.3	14.7	22.5	18	27.3	24	36.9	30	46.5	42	64.2	54	81.2	62	94.7	78	119	105	160</		



公称功率和输出扭矩
类型 WH4
规格 17-26

Nominal Power Rating and Output Torque
Type WH4
Sizes 17-26

公称功率P _{2N} (KW)和公称输出扭矩T _{2N} (KN.m)/Nominal power ratings P _{2N} (kw) and output torque T _{2N} (KN,m)																							
in	n ₁	n ₂	齿轮箱规格/gear unit sizes (17-26)																				
			17		18		19		20		21		22		23		24		25		26		
			P _{2N}	T _{2N}	P _{2N}	T _{2N}	P _{2N}	T _{2N}	P _{2N}	T _{2N}	P _{2N}	T _{2N}	P _{2N}	T _{2N}	P _{2N}	T _{2N}	P _{2N}	T _{2N}	P _{2N}	T _{2N}	P _{2N}	T _{2N}	
100	1500	15	330				495					692					923					1319	
	1000	10	219	210			330	315				461	440				615	588				879	839
	750	7.5	165				247					346					461					659	
112	1500	13.4	294			353		441		508		618		692		824		943				1178	1325
	1000	8.9	195	209	234	250	293	313	337	361	411	439	460	492	547	585	626	669	782	837	880	941	
	750	6.7	146			176		220		253		308		345		410		469		587		660	
125	1500	12	264			316		395		455		553		620		738		844				1055	1187
	1000	8	175	209	211	252	264	315	303	362	359	440	413	493	492	588	563	672	704	840	791	944	
	750	6	132			158		198		228		276		309		369		422		528		593	
140	1500	10.7	235			281		353		405		494		552		658		753				941	1058
	1000	7.1	155	208	187	250	234	313	269	359	328	438	366	490	439	584	499	667	624	834	702	939	
	750	5.4	117			140		176		202		246		275		328		374		468		527	
160	1500	9.4	206			248		310		356		434		485		579		660				826	929
	1000	6.3	138	210	166	253	207	316	238	364	291	444	326	497	387	592	443	677	553	846	623	951	
	750	4.7	103			124		155		179		218		244		291		332		415		467	
180	1500	8.3	170			204		255		293		358		400		476		545				681	766
	1000	5.6	115	197	137	236	172	295	198	340	241	414	270	463	321	553	368	632	460	790	516	888	
	750	4.2	86			103		129		148		181		202		241		276		345		387	
200	1500	7.5	154			184		230		265		322		362		430		492				615	692
	1000	5	102	195	123	234	154	294	176	337	215	410	241	460	287	548	328	627	410	782	462	882	
	750	3.8	76			92		115		132		161		181		215		246		307		346	
224	1500	6.7	137			165		206		237		288		322		384		440				550	618
	1000	4.5	92	197	111	237	138	296	159	340	193	413	217	463	258	551	295	631	368	788	416	889	
	750	3.3	69			83		104		119		145		162		193		221		276		312	
250	1500	6	123			147		184		212		265		289		344		394				492	554
	1000	4	81	194	98	234	123	292	141	337	172	409	192	459	229	548	263	627	328	784	368	880	
	750	3	61			74		92		106		129		144		172		197		246		276	
280	1500	5.4	107			128		161		185		225		252		300		343				429	483
	1000	3.6	71	191	86	229	107	287	124	330	150	401	168	450	200	536	229	612	286	765	322	861	
	750	2.7	53			64		81		93		113		126		150		172		214		242	
315	1500	4.8	95			114		143		164		200		224		267		305				382	429
	1000	3.2	64	191	76	229	95	286	109	329	133	400	149	449	178	534	203	612	255	766	286	860	
	750	2.4	48			57		71		82		100		112		133		152		191		214	
355	1500	4.2	80			100		121		143		171		196		234		267				333	375
	1000	2.8	53	180	67	225	81	274	96	325	114	386	130	441	156	528	178	602	222	754	250	847	
	750	2.1	40			50		61		72		86		98		117		133		167		187	
400	1500	3.8				84				126				176				241				340	
	1000	2.5				55	210			83	316			115	439			159	606			223	853
	750	1.9				41				82				86				119				167	
450	1500	3.3																					
	1000	2.2																					
	750	1.7																					



热功率
类型 WH4
规格 7-26

Thermal Capacities
Type WH4
Sizes 7-26

n₁=750rpm

热功率PG(kw)/Thermal capacities PG(kw)																							
in		齿轮箱规格/Gear unit sizes(7-26)																					
		7	8	9	10	11	12	13	14	15	16	17	18	19	20	21	22	23	24	25	26		
		100	PGA	40.7		56.8		84.2		11.2		150		168		236		323		*	*	*	*
112	PGA	39.2		54.4		83.5		109		144	155	162	173	227	243	318	327	*	*	*	*		
125	PGA	38.1	43.7	52.7	57.1	80.1	93.1	106	120	139	149	156	165	220	233	308	321	*	*	*	*		
140	PGA	36.1	41.9	51.0	54.6	77.5	92.4	103	117	135	143	150	160	212	225	292	321	*	*	*	*		
160	PGA	34.7	40.7	48.2	53.0	73.8	89.0	97.1	113	129	138	144	154	204	217	281	296	*	*	*	*		
180	PGA	33.4	38.7	46.1	51.3	71.2	85.7	93.4	110	127	133	141	148	194	209	277	284	*	*	*	*		
200	PGA	32.1	37.3	44.6	48.4	67.3	81.8	91.7	104	123	130	136	146	188	200	262	280	*	*	*	*		
224	PGA	30.3	35.7	42.9	46.3	64.5	78.8	87.5	99.9	115	127	127	141	180	192	250	264	*	*	*	*		
250	PGA	29.0	34.6	40.9	45.0	61.3	74.4	83.2	97.1	109	118	121	132	171	185	236	252	*	*	*	*		
280	PGA	28.1	32.4	39.7	43.2	58.9	71.6	80.6	92.6	106	112	118	124	164	176	227	238	*	*	*	*		
315	PGA	27.5	31.3	37.8	41.2	57.5	67.9	77.3	89.2	101	108	113	121	161	169	218	229	*	*	*	*		
355	PGA	26.5	30.2	37.2	40.0	54.7	65.3	73.7	85.8	99	104	110	116	153	165	207	220	*	*	*	*		
400	PGA		29.5		38.1		63.8		82.5		102		113		157		210		*	*	*	*	
455	PGA		28.1		37.6		60.6		78.6										*	*	*	*	

n₁=1000rpm

热功率PG(kw)/Thermal capacities PG(kw)																							
in		齿轮箱规格/Gear unit sizes(7-26)																					
		7	8	9	10	11	12	13	14	15	16	17	18	19	20	21	22	23	24	25	26		
		100	PGA	43.6		60.8		90.1		120		161		180		253		346		*	*	*	*
112	PGA	42		58.2		89.4		117		154	166	173	185	243	260	340	350	*	*	*	*		
125	PGA	40.8	46.8																				



公称功率和输出扭矩
类型 WV2
规格 4-18

Nominal Power Rating and Output Torque
Type WV2
Sizes 4-18

公称功率P2s(KW)和公称输出扭矩T2s(KN.m)/Nominal power ratings P2s(kw) and output torque T2s(KN,m)																																
齿轮箱规格/gear unit sizes (4-18)																																
in	n1	n2	4		5		6		7		8		9		10		11		12		13		14		15		16		17		18	
			P2N	T2N	P2N	T2N	P2N	T2N	P2N	T2N	P2N	T2N	P2N	T2N	P2N	T2N	P2N	T2N	P2N	T2N	P2N	T2N	P2N	T2N	P2N	T2N	P2N	T2N	P2N	T2N	P2N	T2N
5	1500	300	201		310				626				986				1517				2262				4024							
	1000	200	133	6.4	206	9.8			417	19.9			657	31.4			1011	48.3			1508	72.0			2682	128						
	750	150	100		154				313				493				758				1131				2011							
5.6	1500	268	182		276				560				881				1416				2051				3594	3977						
	1000	179	122	6.5	185	9.9			374	20.0			588	31.4			946	50.6			1369	73.2			2400	128	2657	142	3837			
	750	134	91		139				280				141				710				1027				1800	1992	2878					
6.3	1500	238	162		246	314			497		623		782		994		1314		1538		1931		2229		3401	3689	5102					
	1000	159	108	6.5	164	9.9	209	12.6	332	20.0	416	25.0	522	31.4	664	39.9	877	52.7	1027	61.8	1289	77.6	1489	90	2272	137	2464	148	3408	205		
	750	119	81		123	157			249		312		391		498		658		770		967		1117		1704	1848	2556					
7.1	1500	211	133		203	260			411		515		647		822		1134		1318		1642		1889		2858	3139	4222					
	1000	141	89	6.0	135	9.2	173	11.8	274	18.6	344	23.3	432	29.3	550	37.3	758	51.4	881	59.7	1098	74.4	1262	86	1909	129	2097	142	2821	191	3327	226
	750	106	67		101	130			206		258		324		412		568		661		823		947		1432	1573	2116					
8	1500	188	120		181	231			367		459		576		733		1042		1217		1543		1765		2546	2856	3761	4436				
	1000	125	79	6.1	121	9.2	154	11.8	243	18.6	305	23.3	383	29.3	487	37.2	692	52.9	809	61.8	1026	78.4	1173	90	1692	129	1898	145	2501	191	2950	225
	750	94	60		90	115			182		229		287		365		519		606		770		880		1269	1424	1876					
9	1500	167	106		161	205			325		408		512		651		925		1117		1390		1621		2262	2536	3341	3941				
	1000	111	71	6.1	107	9.2	136	11.7	216	18.5	270	23.2	340	29.2	432	37.1	614	52.8	742	63.8	923	79.3	1077	93	1503	129	1686	145	2221	191	2620	225
	750	83	53		80	102			162		203		255		324		461		556		692		808		1127	1261	1666					
10	1500	150	95		144	184			292		366		460		584		831		1020		1248		1520		2032	2278	3001	3540				
	1000	100	63	6.0	96	9.2	123	11.7	194	18.5	244	23.3	307	29.3	389	37.2	554	52.9	680	65.0	832	79.5	1013	97	1354	129	1518	145	2000	191	2360	225
	750	75	47		72	92			146		183		230		292		415		510		624		760		1016	1139	1500					
11.2	1500	134	82		124	160			253		316		398		506		719		884		1080		1351		1759	1972	2599	3066				
	1000	89	54	5.8	83	8.8	105	11.3	168	18.0	210	22.5	264	28.2	336	36.0	478	51.1	586	62.7	717	76.7	897	96	1169	125	1310	140	1726	185	2036	218
	750	67	41		62	79			126		157		198		252		358		440		538		673		876	983	1295					
12.5	1500	120			143				284				353		453				791				1210			1766						
	1000	80			95	11.3			186	22.6			242		302	36.1			527	62.9			807	96		1177	141					
	750	60			71				142				187		227				395				605			883						
14	1500	107			127				253				322		404				705				1079									
	1000	71			85	11.3			167	22.4			214		268	35.8			467	62.5			715	96								
	750	54			63				125				161		201				351				537									

采取强制润滑

Forced lubrication required



热功率
类型 WV2
规格 4-11

Thermal Capacities
Type WV2
Sizes 4-11

热功率PG(kw)/Thermal capacities PG(kw)																									
齿轮箱规格/Gear unit sizes(4-11)																									
in	n1	4			5			6			7			8			9			10			11		
		750	1000	1500	750	1000	1500	750	1000	1500	750	1000	1500	750	1000	1500	750	1000	1500	750	1000	1500			
5	PGA	47.1	48.3	35.3	57.2	58.6	*				85.3	77.4				95.9	87.1	*			*	*	*		
	PGB	94.7	113	139	130	155	184				203	246	283			245	297	328			402	487	478		
	PGC	119	137	159	178	206	238				280	319	368			349	398	459			593	677	774		
	PGD	161	194	249	241	291	366				382	468	581			472	578	705			804	984	1144		
5.6	PGA	46.6	47.7	38.6	58.4	59.8	*				86.2	78.3	*			99.4	90.2	*			132	120	*		
	PGB	91.3	109	135	128	153	185				192	232	274			233	282	322			397	481	504		
	PGC	114	132	154	172	199	231				257	293	340			322	367	424			563	643	738		
	PGD	155	187	241	233	282	359				353	432	543			437	535	662			770	943	1126		
6.3	PGA	45.9	47	40	57.3	58.7	*	66.7	68.3	*	83.5	75.8	*	99.0	89.9	*	98.5	89.4	*	108	98.3	*	134	122	*
	PGB	88.0	105	132	121	145	178	142	170	206	178	216	259	216	261	308	219	265	310	248	300	345	364	441	479
	PGC	109	126	147	160	185	215	228	264	306	233	266	308	340	388	449	292	333	385	403	460	531	496	566	651
	PGD	148	179	231	218	263	336	297	359	456	321	393	497	448	548	690	399	489	612	525	643	799	681	834	1010
7.1	PGA	43.9	45	40.6	55.8	57.2	44	67.3	69	50.6	81.8	74.3	*	97.9	88.9	*	98.1	89.1	*	109	99.3	*	145	132	*
	PGB	82.9	99	125	115	137	169	139	166	204	168	203	248	203	246	298	207	250	299	235	284	336	360	436	493
	PGC	100	116	135	148	171	199	222	257	298	214	244	284	313	357	414	268	304	354	370	422	488	478	545	529
	PGD	136	164	213	201	243	313	289	349	447	296	362	462	413	506	642	368	451	570	485	594	747	660	808	996
8	PGA	41.8	42.8	39.9	53.5	54.8	45.1	65.6	67.2	53.4	79.4	72.1	53	94.8	86.1	*	96.3	87.4	*	108	97.7	*	142	129	*
	PGB	77.8	92.9	117	107	128	160	132	157	195	159	192	236	189	229	280	196	237	287	221	267	321	330	400	463
	PGC	93	107	124	136	157	182	205	237	276	198	226	263	283	323	375	248	283	328	336	383	444	422	482	557
	PGD	126	152	198	186	225	290	268	324	417	274	336	430	375	459	586	342	419	533	442	541	686	587	719	896
9	PGA	40.0	41	39.3	51.4	52.7	45.7	62.9	64.5	54.4	77.3	70.2	55.8	91.1	82.7	61.6	94.5	85.8	59.6	105	95.3	*	142	129	*
	PGB	73.6	87.8	111	101	121	153	124	148	186	150	182	226	178	215	266	187	226	277	207	251	306	316	383	452
	PGC	86	98.8	115	125	144	168	189	218	253	186	212	246	260											



热功率
类型 WV2
规格 12-18

Thermal Capacities
Type WV2
Sizes 12-18

热功率PG(kw)/Thermal capacities PG(kw)																						
in		齿轮箱规格/Gear unit sizes(12-18)																				
		12			13			14			15			16			17			18		
		n1	750	1000	1500	750	1000	1500	750	1000	1500	750	1000	1500	750	1000	1500	750	1000	1500		
5	PGA				*	*	*				*	*	*									
	PGB				579	684	574				667	788	486									
	PGC				1178	1344	1524				1642	1821	2040									
	PGD				1516	1838	2019				1966	2383	2386									
5.6	PGA				*	*	*				*	*	*			*	*	*				
	PGB				582	688	646				680	804	618			727	859	565				
	PGC				1163	1289	1470				1590	1763	1992			1874	2055	2307				
	PGD				1476	1789	2044				1925	2333	2489			2218	2689	2739				
6.3	PGA	156	142	*	*	*	*	*	*	*	*	*	*	*	*	*	*	*	*	*		
	PGB	459	556	581	539	637	633	652	771	753	659	779	664	709	838	684	719	850	646			
	PGC	855	976	1120	992	1132	1295	1273	1411	1613	1467	1627	1847	1607	1782	2019	1741	1909	2155			
	PGD	1094	1340	1596	1299	1574	1839	1612	1954	2267	1789	2168	2393	1952	2366	2574	2087	2530	2689			
7.1	PGA	174	158	*	172	151	*	200	176	*	*	*	*	*	*	*	*	*	*	*		
	PGB	451	546	601	539	637	676	650	768	804	640	756	720	609	815	754	709	838	740	759		
	PGC	816	931	1072	961	1097	1261	1219	1352	1552	1360	1508	1722	1484	1645	1875	1629	1787	2031	1750		
	PGD	1044	1278	1556	1271	1541	1848	1563	1895	2261	1673	2028	2331	1818	2204	2505	1968	2386	2666	2110		
8	PGA	171	155	*	175	154	*	206	181	*	*	*	*	*	*	*	*	*	*	*		
	PGB	411	498	564	498	588	646	597	705	768	597	705	713	663	784	775	671	793	756	740		
	PGC	716	817	942	882	978	1126	1069	1185	1364	1223	1356	1553	1381	1531	1751	1478	1621	1851	1635		
	PGD	922	1129	1392	1134	1375	1675	1372	1663	2016	1510	1830	2152	1699	2059	2400	1794	2174	2499	1982		
9	PGA	178	162	*	181	159	*	220	193	*	192	169	*	220	176	*	*	*	*	*		
	PGB	405	490	568	478	565	640	591	699	785	579	684	724	618	730	759	655	774	782	696		
	PGC	693	791	915	801	914	1055	1039	1152	1329	1157	1283	1474	1234	1368	1570	1406	1542	1766	1481		
	PGD	893	1094	1363	1069	1296	1598	1341	1625	1998	1436	1741	2085	1529	1853	2204	1714	2078	2444	1805		
10	PGA	149	153	*	159	157	*	190	188	*	174	172	*	184	182	*	177	175	*	*		
	PGB	369	447	525	453	535	616	543	642	734	544	643	698	596	704	753	624	737	770	676		
	PGC	613	700	810	741	846	978	918	1018	1176	1055	1170	1347	1169	1296	1490	1305	1431	1642	1410		
	PGD	794	972	1218	990	1200	1490	1191	1444	1787	1317	1596	1933	1452	1760	2118	1596	1935	2306	1720		
11.2	PGA	146	150	*	147	145	*	187	185	*	154	162	*	183	181	*	171	169	*	189		
	PGB	352	426	506	403	476	555	519	613	709	492	581	641	560	662	721	556	669	714	643		
	PGC	577	659	764	643	734	849	859	952	1101	929	1030	1186	1066	1182	1360	1155	1267	1457	1312		
	PGD	750	918	1156	863	1046	1306	1119	1356	1588	1164	1411	1722	1333	1616	1960	1419	1720	2068	1601		
12.5	PGA	142	145	*				185	183	*					177	175	*			188		
	PGB	330	400	481				490	579	681					506	598	659			585		
	PGC	529	604	701				796	882	1021					937	1039	1198			1163		
	PGD	690	845	1070				1035	1255	1574					1180	1430	1754			1427		
14	PGA	128	131	*				170	168	*												
	PGB	292	353	428				435	514	611												
	PGC	457	522	605				688	763	884												
	PGD	599	733	931				901	1092	1377												

* 敬请期待
PGA(KW) 齿轮箱不带辅助冷却措施
PGB(KW) 齿轮箱带冷却风扇
PGC(KW) 齿轮箱带内置冷却盘管
PGD(KW) 齿轮箱带冷却风扇和内置冷却盘管

* On request
PGA(KW) Gear units without auxiliary cooling
PGB(KW) Gear units with fan
PGC(KW) Gear units with built-in cooling coil
PGD(KW) Gear units with fan and built-in cooling coil



公称功率和输出扭矩
类型 WV3
规格 4-11

Nominal Power Rating and Output Torque
Type WV3
Sizes 4-11

公称功率P2N(KW)和公称输出扭矩T2N(KN.m)/Nominal power ratings P2N(kw) and output torque T2N(KN.m)																	
in		齿轮箱规格/gear unit sizes (4-11)															
		4		5		6		7		8		9		10		11	
		P2N	T2N	P2N	T2N	P2N	T2N	P2N	T2N	P2N	T2N	P2N	T2N	P2N	T2N	P2N	T2N
12.5	1500	120	72		124				224					369			691
	1000	80	48	5.8	82	9.8			149	17.8				246	29.3		460
14	1500	107	70		114				213					347			667
	1000	71	46	6.2	76	10.1			142	19.0				230	30.7		442
16	1500	94	57		108		124		204		222			320		368	618
	1000	63	45	6.9	72	11.1	86	12.7	137	20.9	148	22.6		214	32.7	246	415
18	1500	83	61		103		114		192		210			309		341	565
	1000	56	41	7.0	69	11.9	77	13.2	129	22.2	142	24.4		208	35.7	230	381
20	1500	75	55		96		108		179		206			294		323	523
	1000	50	37	7.0	63	12.0	72	13.8	119	22.7	137	26.1		195	37.3	215	349
22.4	1500	67	48		85		104		160		194			263		308	467
	1000	45	33	7.0	57	12.1	69	14.8	107	22.9	130	27.9		176	37.7	206	314
25	1500	60	41		71		95		133		167			220		270	390
	1000	40	27	6.6	47	11.2	63	15.0	88	21.1	111	26.4		146	34.9	179	260
28	1500	54	36		64		85		120		150			197		242	352
	1000	36	25	6.6	42	11.3	57	15.2	79	21.2	100	26.7		131	35.1	162	234
31.5	1500	48	32		57		75		107		133			175		216	313
	1000	32	22	6.5	37	11.2	50	15.0	71	21.2	89	26.8		117	35.1	143	208
35.5	1500	42	28		50		67		93		117			154		188	273
	1000	28	19	6.3	33	11.3	44	15.0	62	20.9	77	26.2		102	34.6	125	182
40	1500	38	25		45		60		84		106			139		171	247
	1000	25	17	6.4	29	11.2	39	15.0	55	21.0	70	26.6		91	34.8	112	163
45	1500	33	23		39		52		73		91			121		148	215
	1000	22	15	6.3	25	11.0	34	14.7	48	20.6	61	26.1		80	34.5	98	143
50	1500	30	20		34		46		65		81			106		130	189
	1000	20	13	6.4	23	10.9	30	14.5	43	20.4	53	25.4		70	33.6	86	125
56	1500	27	17		30		41		58		72			95		117	170
	1000	17.9	11	6.1	20	10.7	28	14.7	38	20.3	48	25.4		63	33.5	78	113
63	1500	24	15		27		36		50		65			85		105	151
	1000	15.9	10	5.7	17	10.3	24	14.3	33	20.0	43	25.7		56	33.7	68	100
71	1500	21	13		23		32		41		56			70		91	124
	1000	14.1	9	6.2	15	10.3	21	14.2	28	18.7	38	25.8		48	32.2	61	84
80	1500	18.8					26				49					82	
	1000	12.5					17	13.1			33	25.4					



公称功率和输出扭矩
类型 WV3
规格 12-19

Nominal Power Rating and Output Torque
Type WV3
Sizes 12-19

公称功率P _{2N} (KW)和公称输出扭矩T _{2N} (KN.m)/Nominal power ratings P _{2N} (kw) and output torque T _{2N} (KN,m)																				
齿轮箱规格/gear unit sizes (12-19)																				
in	n ₁	n ₂	12		13		14		15		16		17		18		19			
			P _{2N}	T _{2N}	P _{2N}	T _{2N}	P _{2N}	T _{2N}	P _{2N}	T _{2N}	P _{2N}	T _{2N}	P _{2N}	T _{2N}	P _{2N}	T _{2N}	P _{2N}	T _{2N}		
12.5	1500	120			1048				1741				2573				3298			
	1000	80			698	83.4			1160	139			1715	205			2199	262		
	750	60			524				870				1286				1649			
14	1500	107			960				1611			1741			2293		2705	3082		
	1000	71			636	85.1			1069	143			1155	154	1521	203	1794	240	2044	273
	750	54			477				802				866		1141		1346		1533	
16	1500	94	685		865		1027		1467		1591		2066		2376		2841			
	1000	63	459	70.1	580	88.6	688	105	983	150	1066	153	1385	212	1593	243	1905	291		
	750	47	344		435		516		737		799		1039		1195		1429			
18	1500	83	634		791		930		1350		1460		1825		2189		2628			
	1000	56	427	73.5	533	91.7	628	108	910	156	985	169	1231	212	1477	254	1772	305		
	750	42	321		400		471		683		739		923		1108		1329			
20	1500	75	599		748		865		1261		1377		1649		1978		2474			
	1000	50	399	76.2	498	95.1	576	110	841	161	918	175	1099	210	1319	252	1649	315		
	750	38	299		373		432		631		688		825		989		1236			
22.4	1500	67	557		668		795		1127		1274		1473		1767		2209			
	1000	45	374	80.0	448	95.9	533	114	756	162	856	183	989	212	1187	254	1484	317		
	750	33	280		336		400		567		642		742		890		1113			
25	1500	60	475		558		695		942		1064		1231		1477		1846			
	1000	40	317	75.6	371	88.7	464	111	627	150	710	169	820	196	985	235	1231	294		
	750	30	237		279		348		470		532		615		739		923			
28	1500	54	417		502		625		848		958		1107		1330		1662			
	1000	36	285	76.3	334	89.4	417	111	564	151	639	171	738	197	886	237	1107	296		
	750	27	214		251		312		423		479		553		664		831			
31.5	1500	48	380		446		556		754		852		985		1182		1477			
	1000	32	253	76.1	297	89.3	370	111	502	151	567	171	657	198	788	237	985	296		
	750	24	190		223		278		376		426		492		591		739			
35.5	1500	42	332		390		486		659		745		861		1034		1293			
	1000	28	221	75.1	260	88.0	324	110	439	149	497	168	574	195	689	234	861	292		
	750	21	166		195		243		329		373		431		517		646			
40	1500	38	301		353		440		596		674		779		935		1169			
	1000	25	198	75.6	232	88.7	289	110	392	150	443	169	513	196	615	235	769	294		
	750	18.8	148		174		217		294		332		384		462		577			
45	1500	33	261		307		382		517		585		677		812		1015			
	1000	22	173	74.5	204	87.6	255	110	345	148	390	168	451	194	541	232	677	291		
	750	16.7	130		153		191		259		293		338		406		508			
50	1500	30	230		270		336		456		516		597		715		895			
	1000	20	153	73.0	180	85.7	224	107	304	145	344	164	397	190	477	228	597	285		
	750	15	115		135		168		228		258		298		358		447			
56	1500	27	207		243		303		410		465		537		644		806			
	1000	17.9	137	73.2	162	86.4	200	107	272	145	308	165	355	190	427	228	534	286		
	750	13.4	103		121		150		204		231		266		320		400			
63	1500	24	184		216		269		365		412		477		573		715			
	1000	15.9	122	73.2	143	86.3	179	107	241	145	274	165	315	190	379	228	474	285		
	750	11.9	91		108		134		181		205		237		284		356			
71	1500	21	161		189		236		319		361		417		501		626			
	1000	14.1	107	72.8	126	85.7	158	107	214	145	242	164	280	190	336	228	420	285		
	750	10.6	81		95		118		160		182		210		252		315			
80	1500	18.8	143				211				323				448					
	1000	12.5	96	73.3			140	107			215	164			298	228				
	750	9.4	72				105				161				224					
90	1500	16.7	124				187													
	1000	11.1	83	71.0			124	107												
	750	8.3	62				93													

采取强制润滑

Forced lubrication required



公称功率和输出扭矩
类型 WV3
规格 20-26

Nominal Power Rating and Output Torque
Type WV3
Sizes 20-26

公称功率P _{2N} (KW)和公称输出扭矩T _{2N} (KN.m)/Nominal power ratings P _{2N} (kw) and output torque T _{2N} (KN,m)																		
齿轮箱规格/gear unit sizes (20-26)																		
in	n ₁	n ₂	20		21		22		23		24		25		26			
			P _{2N}	T _{2N}	P _{2N}	T _{2N}	P _{2N}	T _{2N}	P _{2N}	T _{2N}	P _{2N}	T _{2N}	P _{2N}	T _{2N}	P _{2N}	T _{2N}		
12.5	1500	120			4486													
	1000	80			2990	357												
	750	60			2243													
14	1500	107	3470		4235		4764											
	1000	71	2303	308	2810	376	3161	423										
	750	54	1727		2107		2370											
16	1500	94	3183		3927		4361											
	1000	63	2133	326	2631	402	2922	447										
	750	47	1599		1973		2192											
18	1500	83	2920		3650		3996											
	1000	56	1970	339	2462	423	2696	464										
	750	42	1477		1847		2022											
20	1500	75	2737		3463		3752	4617										
	1000	50	1825	349	2308	441	2501	478	3078	588			4397	840				
	750	38	1369		1731		1876		2308				3298					
22.4	1500	67	2541		3093		3462	4124										
	1000	45	1706	365	2078	445	2325	497	2770	593	3166	677	3957	847	4452	952		
	750	33	1280		1558		1744		2077		2374		2968		3339			
25	1500	60	2124		2585		2893	3448										
	1000	40	1416	338	1724	412	1929	460	2298	549	2646	627	3283	784	3694	882		



热功率
类型 WV3
规格 4-9

Thermal Capacities
Type WV3
Sizes 4-9

		热功率PG(kw)/Thermal capacities PG(kw) 齿轮箱规格/Gear unit sizes(4-9)																	
in	n1	4			5			6			7			8			9		
		750	1000	1500	750	1000	1500	750	1000	1500	750	1000	1500	750	1000	1500	750	1000	1500
12.5	PGA	35.1	38.1	39.4	46.8	50.8	50.4				74.3	79.7	76.7				96.1	103	95.4
	PGB	55.8	66.3	84.8	78.7	93.9	118				124	150	186				169	204	250
	PGC	66.7	76.8	94.7	108	124	151				189	218	265				280	323	390
	PGD	82.8	100	131	133	161	209				229	280	362				337	413	529
14	PGA	34.2	37.1	38.6	45.6	49.4	49.6				72.2	77.4	75.7				94.2	101	95.2
	PGB	54	64.4	82.6	76.2	90.9	114				119	144	180				164	198	244
	PGC	64.7	74.5	91.9	103	119	146				182	210	257				272	313	380
	PGD	80.4	97.2	127	128	155	202				221	270	350				326	399	514
16	PGA	32.5	35.2	36.8	44.2	47.9	48.3	51.1	55.4	55.4	69	74	72.9	80.4	86.2	83.3	92.7	99.4	94.3
	PGB	51.4	61.3	78.6	73.3	87.5	110	83.8	100	126	113	137	172	131	158	196	159	193	239
	PGC	61.4	70.8	87.4	99.8	115	141	111	128	157	174	200	244	194	223	272	264	304	369
	PGD	78.3	92.2	121	123	149	195	137	165	216	210	257	334	233	285	369	317	388	500
18	PGA	31.6	34.3	35.9	42.9	46.5	47.2	49.5	53.7	54.1	66.9	71.7	71.1	77.6	83.2	81.1	90	96.5	92.5
	PGB	49.9	59.5	76.4	71	84.8	107	81.4	97.1	122	110	133	167	126	153	191	154	187	232
	PGC	59.5	68.5	84.7	96.3	111	136	106	122	150	167	192	235	188	217	265	254	293	357
	PGD	74.1	89.5	117	119	144	189	132	159	208	202	247	322	226	277	359	306	375	485
20	PGA	29.9	32.4	34	41.1	44.6	45.6	47.9	51.9	52.6	64.3	68.9	68.8	74	79.4	78	86.5	92.8	89.8
	PGB	47	56.1	72.1	68.1	81.3	103	78.3	93.5	118	105	127	161	120	145	182	148	179	223
	PGC	56.2	64.8	80.1	92.9	107	131	102	118	145	160	184	225	177	204	249	243	280	342
	PGD	69.8	84.3	111	114	138	181	127	154	201	193	236	307	213	261	340	294	360	466
22.4	PGA	29.1	31.6	33.3	40.6	44	45.1	46.5	50.4	51.4	62.3	66.8	67.2	72.2	77.4	76.7	84.6	90.7	88.6
	PGB	45.7	54.6	70.3	67	80	101	76	90.7	115	102	123	155	116	141	177	145	175	218
	PGC	54.7	63	77.9	91.1	105	130	100	115	142	154	178	218	172	198	242	236	272	332
	PGD	68	82.2	108	113	137	180	123	149	195	185	226	296	207	253	330	284	348	452
25	PGA	27.8	30.1	31.9	38.5	41.8	43.3	44.8	48.6	50.1	60.6	65	66.2	69.7	74.7	75.2	81.4	87.3	86.9
	PGB	43.3	51.7	66.7	63.3	75.5	96.6	72.8	86.9	110	98.3	119	151	111	134	170	137	166	209
	PGC	51.6	59.4	73.6	86.3	99.4	122	99.4	110	135	147	169	208	164	189	232	220	253	310
	PGD	64.1	77.4	102	106	128	168	118	142	189	177	217	284	198	243	317	265	324	422
28	PGA	26.7	29	30.9	37.4	40.6	42.5	44.3	48	50	57.9	62.1	64.1	67.8	72.7	74.4	78.2	83.9	85
	PGB	41.4	49.4	63.9	60.9	72.7	93.3	71.6	85.5	109	92.5	112	143	107	130	165	130	157	199
	PGC	48.6	56	69.4	81.6	94	116	94.6	109	134	135	156	193	159	183	225	204	235	288
	PGD	60.5	73.1	96.7	100	121	159	117	141	185	164	201	264	191	234	306	247	302	395
31.5	PGA	25.4	27.5	29.4	35.6	38.6	40.7	42	45.5	47.8	55.2	59.2	61.7	65.6	70.3	72.7	75.2	80.6	82.7
	PGB	39.2	46.8	60.7	57.6	68.7	88.5	67.5	80.6	103	87.6	106	136	103	125	160	123	149	190
	PGC	45.6	52.5	65.2	76	87.6	108	88.5	102	126	127	146	180	151	174	215	191	220	271
	PGD	56.8	68.6	90.8	93.5	113	149	110	133	175	154	188	247	181	222	292	230	282	375
35.5	PGA	23.9	25.9	27.8	33.6	36.4	38.6	40.6	44	46.4	52.6	56.4	59.1	62.5	67	69.8	71.7	76.9	79.6
	PGB	36.7	43.8	56.8	53.9	64.3	83	64.9	77.5	99.8	82.6	100	129	98.3	119	152	118	141	181
	PGC	41.9	48.3	59.9	69.6	80.2	99.3	84	96.8	119	117	135	167	141	162	200	174	201	248
	PGD	52.2	63.1	83.7	86.1	104	138	104	126	166	142	174	229	169	207	272	212	280	341
40	PGA	20.8	22.6	24.3	29.2	31.7	33.7	35.5	41.8	44.3	46.1	49.4	52	59.8	64.1	67.1	67.2	72.1	75
	PGB	31.9	38.1	49.4	46.4	55.5	71.6	61.4	73.3	94.6	72	87.1	112	92.5	112	144	108	131	168
	PGC	35.3	40.7	50.5	57.9	66.7	82.7	78.5	90.4	111	97.2	112	138	131	151	187	158	182	224
	PGD	44	53.2	70.6	72	87	115	96.8	117	155	118	144	191	158	193	254	192	235	305
45	PGA	20.4	22.1	23.8	28.5	30.9	32.9	36.2	39.3	41.8	44.8	48	50.8	56.8	60.9	64	61.9	66.4	69.4
	PGB	31.2	37.2	48.3	45.2	54	69.8	57.4	68.5	88.5	69.5	84.1	108	87.6	106	137	99.1	120	154
	PGC	34.3	39.5	49	55.8	64.3	79.7	72	82.9	102	93.7	108	133	121	139	172	142	164	202
	PGD	42.9	51.8	68.7	69.5	84	111	88.6	107	142	114	138	183	146	179	236	172	211	279
50	PGA	20.7	22.4	24.2	28.4	30.8	33	31.7	34.4	36.8	44.4	47.6	50.7	50	53.6	56.9	61.1	65.5	69.3
	PGB	31.3	37.4	48.7	45.7	53.3	69.2	49.8	59.4	76.9	68.2	82.5	106	76.4	92.5	119	96.7	117	151
	PGC	34.3	39.5	49.1	54.3	62.6	77.7	60.1	69.2	85.8	90.3	104	129	101	116	144	135	156	194
	PGD	42.7	51.6	68.5	67.8	81.9	108	74.7	90.3	119	109	134	177	122	149	197	166	203	269
56	PGA	19.1	20.7	22.4	26.3	28.5	30.7	31	33.1	36.2	41.3	44.3	47.5	48.6	52.1	55.7	56.6	60.7	64.8
	PGB	28.8	34.4	44.8	41.3	49.3	64	48.4	57.8	75.1	63.4	76.7	99.5	74	89.6	116	89.2	108	140
	PGC	30.9	35.6	44.2	49	56.4	70.1	57.9	66.7	82.9	82.2	94.7	117	96.3	111	138	122	140	174
	PGD	38.7	46.8	62.1	61.3	74.1	98.3	72.2	87.2	115	100	122	162	117	143	190	149	182	241
63	PGA	18.4	19.9	21.6	25.3	27.4	29.5	30.8	33.4	36	39.9	42.8	46.1	48	51.5	55.2	54.7	58.7	62.8
	PGB	27.7	33.1	43.2	39.6	47.3	61.6	47.8	57.1	74.2	61.2	74.1	96.2	72.8	88.1	114	85.9	104	135
	PGC	29.2	33.7	41.9	46.3	53.3	66.2	56.4	65	80.8	77.9	89.8	111	93.7	108	134	115	132	164
	PGD	36.7	44.3	58.9	58	70.1	93	70.4	85.1	112	95	116	154	114	140	185	141	173	229
71	PGA	17	18.4	20	24.1	26.1	28.2	28.4	30.8	33.3	38	40.8	43.9	44.8	47.8	51.4	51.3	55	59
	PGB	25.7	30.7	40	37.6	44.9	58.5	44.1	52.6	68.4	58.2	70.5	91.7	67.5	81.7	106	80.8	97.8	126
	PGC	26.6	30.6	38	42.8	49.3	61.3	51	58.8	73	72.1	83.1	103	85.3	98.3	122	103	119	148
	PGD	33.4	40.4	53.7	54	65.2	86.5	63.8	77.1	102	88	108	143	104	127	168			



公称功率和输出扭矩
类型 WV4
规格 16-26

Nominal Power Rating and Output Torque
Type WV4
Sizes 16-26

公称功率P _{2N} (KW)和公称输出扭矩T _{2N} (KN.m)/Nominal power ratings P _{2N} (kw) and output torque T _{2N} (KN,m)																											
in	n ₁	n ₂	齿轮箱规格/gear unit sizes (16-26)																								
			16		17		18		19		20		21		22		23		24		25		26				
			P _{2N}	T _{2N}	P _{2N}	T _{2N}	P _{2N}	T _{2N}	P _{2N}	T _{2N}	P _{2N}	T _{2N}	P _{2N}	T _{2N}	P _{2N}	T _{2N}	P _{2N}	T _{2N}	P _{2N}	T _{2N}	P _{2N}	T _{2N}	P _{2N}	T _{2N}			
80	1500	18.8			413					620					867						1157					1653	
	1000	12.5			274	209				412	314				576	440					769	587				1099	810
	750	9.4			206					309					432						576					825	
90	1500	16.7	317		366		440		550		633		771		862		1028		1175		1468				1652		
	1000	11.1	211	181	244	209	292	251	365	314	420	361	512	440	573	493	683	587	780	671	975	838	1098	944			
	750	8.3	158		183	219			274		315		384		430		512		585		7328				824		
100	1500	15	285		330		395		495		568		692		775		923		1065		1319				1484		
	1000	10	190	181	219	210	264	252	330	315	379	362	461	440	517	493	615	588	704	672	879	839	989	945			
	750	7.5	143		165		198		247		284		346		387		461		528		659				747		
112	1500	13.4	254		294		353		441		508		618		692		824		943		1178				1325		
	1000	8.9	169	181	195	209	234	250	293	313	337	361	411	439	460	492	547	585	626	669	782	837	880	941			
	750	6.7	127		146		176		220		253		308		345		410		469		587				660		
125	1500	12	228		264		316		395		455		553		620		738		844		1055				1187		
	1000	8	151	180	175	209	211	252	264	315	303	362	369	440	413	493	492	588	563	672	704	840	791	944			
	750	6	113		132		158		198		225		276		309		369		422		528				593		
140	1500	10.7	189		220		263		329		378		461		515		614		703		878				988		
	1000	7.1	125	168	145	194	174	233	219	292	251	335	306	409	342	457	408	545	466	622	582	778	656	877			
	750	5.4	94		109		131		164		188		229		257		306		349		437				492		
160	1500	9.4	167		192		231		289		332		405		453		540		616		771				867		
	1000	6.3	112	171	128	196	155	237	193	295	222	340	271	415	304	464	362	553	414	632	516	789	581	888			
	750	4.7	84		96		116		145		167		204		228		271		310		387				436		
180	1500	8.3	147		170		204		255		293		358		400		476		545		681				766		
	1000	5.6	99	170	115	197	137	236	172	295	198	340	241	414	270	463	321	553	368	632	460	790	516	888			
	750	4.2	74		86		103		129		148		181		202		241		276		345				387		
200	1500	7.5	132		154		184		230		265		322		362		430		492		615				692		
	1000	5	88	168	102	195	123	234	154	294	176	337	215	410	241	460	287	548	328	627	410	782	462	882			
	750	3.8	66		76		92		115		132		161		181		215		246		307				346		
224	1500	6.7	119		137		165		206		237		288		322		384		440		550				618		
	1000	4.5	79	170	92	197	111	237	138	296	159	340	193	413	217	463	258	551	295	631	368	788	416	889			
	750	3.3	60		69		83		104		119		145		162		193		221		276				312		
250	1500	6	103		119		143		179		205		250		280		333		382		477				537		
	1000	4	68	163	79	188	95	227	119	284	137	327	166	397	186	445	222	531	255	608	318	760	357	853			
	750	3	51		59		71		89		103		125		140		167		191		239				268		
280	1500	5.4	92		107		128		161		185		225		252		300		343		429				483		
	1000	3.6	62	165	71	191	86	229	107	287	124	330	150	401	168	450	200	536	229	612	286	765	322	861			
	750	2.7	46		53		64		81		93		113		126		150		172		214				242		
315	1500	4.8	82		95		114		143		164		200		224		267		305		382				429		
	1000	3.2	54	163	64	191	76	229	95	286	109	329	133	400	149	449	178	534	203	612	255	766	286	860			
	750	2.4	41		48		57		71		82		100		112		133		152		191				214		
355	1500	4.2	72				100				143				196				267						375		
	1000	2.8	48	161			67	225			96	325			130	441			178	602				250	847		
	750	2.1	36				50				72				98				133						187		
400	1500	3.8																									
	1000	2.5																									
	750	1.9																									



热功率
类型 WV4
规格 5-26

Thermal Capacities
Type WV4
Sizes 5-26

n₁=750rpm

热功率PG(kw)/Thermal capacities PG(kw)																										
in		齿轮箱规格/Gear unit sizes(7-26)																								
		5	6	7	8	9	10	11	12	13	14	15	16	17	18	19	20	21	22	23	24	25	26			
		80	PGA	26.7		39.6		56		84.6		113		151		171		234		328		*		*		
90	PGA	26		38.3		54.7		82.1		110		145	156	163	176	224	239	317	332	*	*	*	*	*	*	
100	PGA	24.8	28.6	36.2	42.3	51.9	56.4	78.8	94.3	105	121	136	149	153	168	212	230	298	321	*	*	*	*	*	*	
112	PGA	23.9	27.9	34.9	41.1	50	55.1	75.1	91.2	99.9	118	130	148	147	158	202	217	289	301	*	*	*	*	*	*	
125	PGA	22.9	26.7	33.3	38.9	47.6	52.3	71.9	87.1	95.3	111	123	135	139	150	191	206	272	292	*	*	*	*	*	*	
140	PGA	21.8	25.7	31.7	37.5	44.9	50.3	68	82.9	91.2	106	120	128	135	144	185	197	262	275	*	*	*	*	*	*	
160	PGA	20.1	24.5	28.9	35.7	41.1	47.9	62	79.5	86.3	103	113	123	127	138	175	190	248	265	*	*	*	*	*	*	
180	PGA	19.7	23.4	28.1	34	40.1	45.5	60.3	75.3	81.5	96.2	106	116	120	130	163	178	232	251	*	*	*	*	*	*	
200	PGA	19	21.6	27.9	31	39.2	41.7	59	68.7	79.6	92	105	109	118	123	163	167	224	234	*	*	*	*	*	*	
224	PGA	17.7	21.2	26	30.3	36.7	40.5	55.5	67.1	74.6	87.1	98.1	108	109	121	152	167	209	227	*	*	*	*	*	*	
250	PGA	17.3	20.3	25.1	30	35.4	39.7	53.7	65.5	72.2	84.6	95.3	101	106	114	148	157	203	212	*	*	*	*	*	*	
280	PGA	16.4	19	23.5	28	33.7	37.2	51.4	61.5	68.2	79.6	88.7	97.1	100	109	138	150	193	205	*	*	*	*	*	*	
315	PGA	15.4	18.5	22	26.9	31.7	35.9	47.9	59.5	65	77	83.8	92	94.3	103	131	143	180	196	*	*	*	*	*	*	
355	PGA		17.7		25.3		34.2		56.8		72.7		86.3		97.1		135		183		*		*	*	*	
400	PGA		16.5		23.7		32.2		53		69.2										*		*	*	*	

n₁=1000rpm

热功率PG(kw)/Thermal capacities PG(kw)																										
in		齿轮箱规格/Gear unit sizes(7-26)																								
		5	6	7	8	9	10	11	12	13	14	15	16	17	18	19	20	21	22	23	24	25	26			
		80	PGA	28.6		42.4		60		90.6		121		162		183		250		351		*		*		
90	PGA	27.9		41		58.6		87.9		118		155	167	175	188	240	256	339								



实际传动比
类型 WH1..., WH2..., WH3..., WH4...
规格 3-14

Actual ratios
Type WH1..., WH2..., WH3..., WH4...
Sizes 3-14

实际传动比 I/Actual ratios I 齿轮箱规格 /Gear Units Sizes												
i _N	3	4	5	6	7	8	9	10	11	12	13	14
1.25	1.250		1.258		1.250		1.250		1.265		0.000	
1.4	1.400		1.414		1.400		1.400		1.406		1.400	
1.6	1.571		1.593		1.571		1.571		1.621		1.593	
1.8	1.769		1.800		1.769		1.769		1.815		1.800	
2.0	2.000		2.000		2.000		2.000		2.040		2.000	
2.24	2.227		2.227		2.273		2.273		2.208		2.227	
2.5	2.550		2.550		2.500		2.476		2.500		2.500	
2.8	2.789		2.789		2.789		2.789		2.800		2.789	
3.15	3.150		3.190		3.143		3.200		3.143		3.158	
3.55	3.611		3.500		3.579		3.526		3.579		3.500	
4.0	3.941		3.944		4.059		4.050		3.944		3.944	
4.5	4.556		4.421		4.444		4.421		4.421		4.421	
5.0	4.941		5.000		5.000		4.947		5.000		5.000	
5.6	5.579		5.611		5.526		5.647		5.526		5.611	
6.3		6.271	6.188		6.375		6.370		6.188		6.188	
7.1		7.088	6.966		7.138		7.200		6.966		6.966	
8.0		8.046	7.875	7.759	7.715	7.995	8.000	7.869	7.875	7.759	7.875	7.759
9.0		8.770	8.770	8.736	8.686	8.953	8.909	8.894	8.949	8.736	8.949	8.736
10		9.844	10.41	9.875	9.833	9.677	10.200	9.882	10.041	9.875	9.750	9.875
11.2		11.097	10.984	10.997	11.013	10.894	11.158	11.005	10.984	11.222	10.984	11.222
12.5		12.600	12.403	12.591	12.674	12.333	12.762	12.600	12.375	12.591	12.600	12.226
14		13.885	14.219	13.773	14.077	13.813	14.000	13.783	14.092	13.773	13.885	13.773
16		15.750	15.518	15.553	15.515	15.896	15.778	15.765	15.982	15.518	15.947	15.800
18		18.030	17.938	17.830	17.389	17.656	17.684	17.294	17.500	17.617	17.408	17.411
20		19.469	19.456	19.460	19.898	19.459	20.000	19.490	19.688	20.040	19.480	19.997
22.4		22.531	21.967	22.493	21.737	21.811	22.444	21.845	21.760	21.944	22.267	21.829
25			25.083	24.397	24.665	24.957	24.750	24.706	25.100	24.688	25.083	24.428
28			28.350	27.546	27.878	27.263	27.865	27.725	28.107	27.286	28.350	27.922
31.5			31.500	31.454	31.648	30.936	31.500	30.574	30.379	31.475	31.500	31.454
35.5			35.250	35.550	34.495	34.965	35.080	34.422	34.202	35.245	35.080	35.550
40			39.375	40.359	38.719	39.695	40.163	38.912	38.719	38.095	40.163	39.500
45			43.750	43.989	43.647	43.265	43.934	43.334	43.365	42.888	43.934	43.989
50			49.500	49.375	49.560	48.563	49.613	49.613	49.904	48.552	50.250	50.363
56			56.368	55.659	54.614	54.743	56.875	54.272	55.429	54.378	55.125	55.092
63			62.213	63.200	61.950	62.160	62.074	61.286	61.090	62.578	62.125	63.012
71			70.875	69.645	70.916	68.499	71.750	70.257	68.471	69.506	69.632	69.125
80			76.897	79.000	76.577	77.700	77.824	76.679	78.349	76.604	78.750	77.903
90			86.625	90.434	88.623	88.946	87.868	88.632	85.589	85.861	88.375	87.316
100			97.653	100.578	96.046	100.333	96.135	97.120	98.247	97.453	98.750	
112				113.014	112.252	111.154	113.400	108.543	109.768	107.326	109.720	110.819
125					125.722	126.148	126.000	123.941	124.615	121.785	124.031	122.203
140					141.437	140.790	141.000	140.082	135.824	137.645	138.126	137.585
160					157.153	157.685	157.500	155.647	152.455	156.264	158.140	155.531
180					176.011	177.396	175.000	174.176	171.858	170.319	172.991	173.205
200					197.563	197.107	198.000	194.559	195.143	191.174	195.349	198.302
224					224.976	220.759	225.474	216.176	215.042	215.505	223.945	216.926
250					248.451	247.791	248.850	244.588	243.928	244.703	244.415	244.962
280					277.912	282.174	283.500	278.526	279.234	269.656	282.516	280.820
315					314.305	311.616	307.588	307.403	301.522	305.878	306.430	306.488
355					341.807	348.567	346.500	350.206	348.953	350.150	345.982	354.266
400						394.213		379.962		378.099		384.254
450						428.707		428.029		437.576		433.850



实际传动比
类型 WH1..., WH2..., WH3..., WH4...
规格 15-26

Actual ratios
Type WH1..., WH2..., WH3..., WH4...
Sizes 15-26

实际传动比 I/Actual ratios I 齿轮箱规格 /Gear Units Sizes												
i _N	15	16	17	18	19	20	21	22	23	24	25	26
0.000			0.000		0.000							
0.000			0.000		0.000							
1.593			1.600		1.586							
1.800			1.786		1.778							
2.000			2.000		2.000							
2.227			2.250		2.261							
2.500			2.545		2.500							
2.789			2.762		2.800							
3.200			3.105		3.190							
3.526			3.524		3.550							
4.000			3.947		4.408							
4.529			4.526		4.579							
4.944			4.944		5.000							
5.667			5.556		5.611							
6.483			6.271		6.282		6.370					
7.259	7.341	7.088	7.167	7.100	7.167	7.200	7.214					
8.160	8.220	7.875	8.100	7.889	8.100	8.000	8.153					
8.833	9.240	8.770	9.000	8.785	9.100	8.909	9.059					
10.000	10.002	9.844	10.023	9.861	10.023	10.000	10.088					
11.200	11.324	10.984	11.250	11.003	11.250	11.158	11.324					
12.571	12.682	12.434	12.553	12.622	12.553	12.800	12.635					
14.316	14.235	13.781	14.211	13.909	14.400	14.105	14.494					
15.778	16.211	15.531	15.750	15.778	15.868	16.000	15.972					
17.684	17.866	17.408	17.750	17.866	18.000	18.118	18.118					
20.000	20.025	19.688	19.895	19.503	20.382	19.778	20.516					
22.050	22.647	21.705	22.500	21.744	22.250	22.500	22.395					
24.750	24.968	24.363	24.806	24.406	24.806	25.931	25.478					
27.865	28.026	27.430	27.844	27.478	27.844	29.037	29.363					
31.500	31.553	31.008	31.349	31.063	31.349	32.640	32.880					
35.795	35.669	35.236	35.438	35.298	35.438	35.333	36.960					
40.163	40.533	39.535	40.270	38.458	40.270	40.000	40.010					
43.934	45.478	43.248	45.183	43.324	43.875	44.800	45.294					
49.500	49.749	48.727	49.426	49.700	49.426	50.286	50.729					
56.368	56.051	55.488	55.688	54.768	56.700	57.263	56.941					
63.926	63.829	62.928	63.414	62.902	62.482	63.111	64.842					
70.000	72.387	68.906	71.917	68.664	71.761	70.737	71.464					
78.750	79.265	77.520	78.750	76.839	78.336	80.000	80.099					
87.039	89.173	85.679	88.594	87.706	87.661	88.421	90.588					
100.402	98.559	98.833	97.919	98.940	100.059	99.000	100.124					
112.428	113.690	110.671	112.952	111.825	112.875	111.462	112.103					
121.517	127.308	119.619	126.481	124.250	127.575	126.000	126.214					
136.806	137.600	134.669	136.707	138.369	141.750	143.182	142.676					
154.875	154.913	152.455	153.907	158.419	157.858	160.650	162.132					
173.460	175.373	170.750	174.234	173.296	180.731	175.737	181.913					
199.817	196.418	196.498	195.143	198.208	197.704	198.000	198.996					
221.716	226.037	218.251	224.569	217.438	226.125	225.474	224.206					
244.358	251.061	240.540	249.430	245.049	248.063	255.706	255.316					
273.884	276.700	269.605	274.903	274.658	279.563	280.000	289.549					
313.394	310.134	308.497	308.120	310.625	313.342	315.000	317.059					
342.355	354.873	337.006	352.568	348.590	354.375	348.158	356.691					
	387.667		385.150		397.688</							



实际传动比
类型 WV2..., WV3..., WV4...
规格 4-14

Actual ratios
Type WV2..., WV3..., WV4...
Sizes 4-14

实际传动比 I/Actual ratios I											
齿轮箱规格 /Gear Units Sizes											
i_N	4	5	6	7	8	9	10	11	12	13	14
5.0	5.054	4.998		4.992		5.077		4.958		4.958	
5.6	5.636	5.649		5.643		5.739		5.603		5.603	
6.3	6.322	6.375	6.267	6.368	6.262	6.286	6.271	6.188	6.128	6.375	6.218
7.1	6.934	7.046	7.084	7.039	7.078	7.158	7.090	7.125	7.026	7.125	7.026
8.0	7.978	7.875	7.994	8.085	7.987	8.222	7.765	7.875	7.759	8.094	7.994
9.0	8.890	8.801	8.836	8.792	8.828	8.941	8.842	8.801	8.935	8.801	8.935
10	9.837	9.844	9.875	10.079	10.141	10.250	10.157	10.090	9.875	10.090	10.149
11.2	11.327	11.207	11.037	11.195	11.027	11.077	11.045	10.904	11.037	11.207	11.037
12.5	12.531	12.827	12.344	12.174	12.642	12.786	12.622	12.496	12.652	12.904	12.652
14	14.222	14.485	14.053	13.936	14.041	13.923	13.683	14.229	13.673	14.169	14.053
16	16.135	15.639	16.138	15.661	15.435	16.032	15.885	15.875	16.036	15.771	16.077
18	18.480	17.928	18.223	18.107	17.669	17.487	17.298	17.804	18.261	18.325	17.653
20	20.151	19.859	19.610	20.201	19.643	19.990	19.805	19.657	19.906	19.990	19.650
22.4	22.520	22.193	22.481	22.527	22.711	22.598	21.602	22.221	22.326	22.598	22.978
25	25.234	24.868	24.902	25.269	25.337	25.500	24.694	25.075	24.650	24.750	25.067
28	28.599	28.184	27.830	27.714	28.255	28.184	27.915	27.714	27.865	28.184	28.337
31.5	31.963	31.500	31.184	31.886	31.693	31.500	31.500	31.835	31.443	32.375	31.036
35.5	35.724	35.206	35.342	35.530	34.761	35.206	34.816	34.619	34.753	35.206	35.342
40	40.569	39.981	39.500	39.314	39.993	39.375	38.912	39.687	39.921	40.359	40.597
45	45.486	44.827	44.147	45.271	44.563	44.827	43.490	44.080	43.411	43.615	44.147
50	50.404	49.673	50.135	50.037	49.310	49.637	48.640	48.845	49.766	49.673	50.609
56	55.936	56.438	56.212	55.497	56.781	56.438	55.374	55.497	55.275	56.438	54.692
63	62.595	63.000	62.288	63.241	62.758	63.000	61.361	61.950	61.250	61.688	62.288
71	70.585	70.875	70.771	70.984	69.606	70.875	69.717	69.694	69.591	69.563	70.771
80		80.115	79.000	79.260	79.319	79.435	77.824	79.542	77.683	78.712	77.354
90		87.868	88.875	88.577	89.031	88.773	87.551	88.701	87.394	88.979	87.229
100		98.206	100.462	99.254	99.410	99.474	98.125	99.497	99.743	100.406	98.703
112		109.760	110.184	112.488	111.096	112.737	109.660	109.126	111.228	110.975	111.577
125		124.646	123.147	125.722	124.488	126.000	122.879	125.551	124.766	124.031	125.906
140		139.755	137.635	140.513	141.087	140.824	139.263	139.900	136.840	138.623	139.160
160		162.417	156.302	159.570	157.685	159.923	155.647	154.801	157.437	155.039	155.531
180		175.825	175.248	178.912	176.237	179.308	173.958	178.255	175.430	176.506	173.829
200		192.180	203.666	198.254	200.139	198.692	197.552	197.019	194.115	195.588	194.414
224		217.055	220.478	220.014	224.398	225.750	221.498	218.519	223.526	222.223	221.333
250		246.531	240.988	246.206	248.658	252.000	245.443	249.010	247.055	248.063	245.261
280		271.688	272.180	277.636	275.949	283.550	278.868	279.501	274.016	279.070	278.660
315		306.906	309.142	309.067	308.800	309.750	311.294	304.910	312.251	304.910	311.063
355			340.688		348.222		350.206		350.485		349.945
400			384.851		387.643		382.632		382.348		382.348



实际传动比
类型 WV2..., WV3..., WV4...
规格 15-26

Actual ratios
Type WV2..., WV3..., WV4...
Sizes 15-26

实际传动比 I/Actual ratios I												
齿轮箱规格 /Gear Units Sizes												
	15	16	17	18	19	20	21	22	23	24	25	26
5.037												
5.692	5.704	5.603										
6.261	6.446	6.163										
7.048	7.090	7.125	7.043									
7.778	7.980	8.094	8.143									
8.941	8.807	8.801	9.250									
9.750	10.125	10.090	10.059									
11.077	11.040	10.904	11.531									
12.467	12.543	12.376	12.462	12.243			12.327					
14.095	14.167	13.476	14.202	13.903	14.018	13.998	14.009					
16.230	16.017	15.658	15.465	15.895	15.917	16.119	15.906					
17.778	18.379	17.792	17.895	17.515	18.133	17.762	18.252					
19.833	20.131	19.523	20.333	19.868	19.982	20.148	20.113					
22.413	22.458	22.063	22.313	22.453	22.667	22.769	22.815					
24.750	25.380	25.102	25.215	24.696	25.615	25.043	25.783					
28.500	28.026	28.055	28.688	27.799	28.174	28.190	28.358					
31.500	32.272	31.869	32.063	30.679	31.714	31.111	31.922					
35.206	35.669	34.656	36.422	35.268	35.000	35.765	35.299					
40.359	39.865	39.729	39.607	38.458	40.235	39.000	40.498					
43.615	45.701	44.127	45.404	43.692	43.875	44.308	44.162					
49.673	49.388	48.897	50.430	48.547	49.846	49.231	50.172					
55.125	56.247	55.556	55.882	55.222	55.385	56.000	55.747					
61.688	62.421	60.724	63.492	61.796	63.000	62.667	63.412					
69.563	69.852	68.476	69.389	69.685	70.500	70.667	70.961					
78.629	78.769	77.400	78.258	78.851	79.500	79.333	80.020					
88.885	89.036	87.496	88.457	89.136	89.957	89.654	89.833					
100.300	100.649	98.733	99.995	97.625	101.690	99.000	101.520					
110.858	113.575	109.126	112.838	111.171	111.375	114.000	112.103					
127.342	125.530	125.352	124.715	127.701	126.829	126.000	129.088					
138.476	144.196	136.313	143.259	138.868	145.688	140.824	142.676					
157.747	156.804	156.266	155.786	159.195	158.426	161.438	159.462					
176.319	179.757	173.564	178.590	172.038	181.617	174.462	182.804					
195.381	199.656	192.328	198.359	195.933	196.269	198.692	197.552					
221.988	221.240	218.519	219.803	222.615	223.529	220.500	224.990					
247.800	251.368	243.928	249.736	243.323	253.969	246.750	249.684					
278.775	280.597	274.419	278.775	274.385	277.594	278.250	279.408					
304.588	315.672	299.828	313.622	305.448	313.031	309.750	315.077					
	344.901		342.661		348.469		350.746					

在输出轴 d_2 上允许的
附加径向力
实心轴 (S)

Permissible Additional Radial
Forces on Output Shaft d_2
Solid Shaft (S)

作用力在轴伸中部
Application of force on centre of shaft end

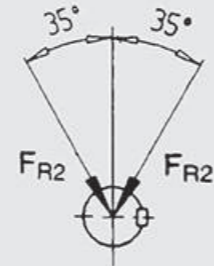
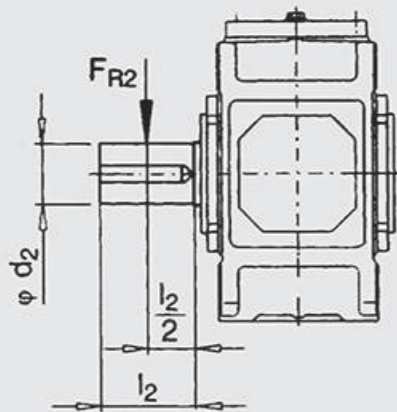

允许的作用力方向
Permissible direction of force

表1/Table1

允许的附加径向力 $F_{R2}(kN)$,作用在输出轴轴伸中部 3) Permissible additional radial forces $F_{R2}(kN)$ with application of force on centre of shaft end 3)																	
类型 Type	布置形式 Design	齿轮箱规格 /Gear Units Sizes 1) 4)															
		3	4	5	6	7	8	9	10	11	12	13	14	15	16	17	18
WH1SH	A/B	2)	-	2)	-	2)	-	2)	-	2)	-	2)	-	2)	-	2)	-
WH2S.	A/B/G/H	-	10	22	22	30	30	30	45	64	64	150	150	140	205	205	205
	C/D	-	10	13	13	18	18	10	28	35	35	112	112	85	135	135	135
WV2S.	A/C	-	13	27	27	27	37	38	55	78	78	160	160	150	210	210	210
	B/D	-	12	15	15	17	17	10	30	35	38	110	110	75	145	100	100
WH3S.	A/B/G/H	-	-	29	29	40	40	40	60	85	85	190	190	185	265	265	265
WH4S.	C/D	-	-	-	-												
WV3S.	A/C	-	14	29	29												
WV4S.	A/C	-	-	-	-												
WH3S.	C/D	-	-	18	18	26	26	18	40	50	50	150	150	120	185	185	190
WH4S.	A/B	-	-	-	-												
WV3S.	B/D	-	9	18	18												
WV4S.	B/D	-	-	-	-												

在输出轴 d_2 上允许的
附加径向力
实心轴 (S)

Permissible Additional Radial
Forces on Output Shaft d_2
Solid Shaft (S)

作用力不在轴伸中部
Application of force outside the
centre of the shaft end

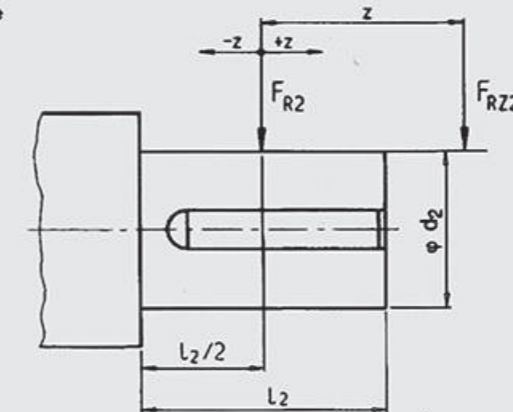

F_{R22} 允许的外部径向力
Permissible external radial force

F_{R2} 允许的附加径向力, 根据第 58 页
上的表 1 确定
Permissible additional radial force
acc. to table 1 page 58

k 作用力系数根据下表确定
Factor of application of force acc.
to table

$$F_{R22} = F_{R2} \times k$$

表 2/Table 2

作用力系数K/Factor of application of force K															
规格 Size	距离z.mm/Distance z in mm														
	-200	-150	-100	-75	-50	-25	0	25	50	75	100	150	200	250	300
3					1.21	1.09	1.00	0.85	0.74	0.65	0.58	0.48			
4					1.17	1.08	1.00	0.86	0.76	0.68	0.62	0.52	0.44		
5+6				1.22	1.44	1.06	1.00	0.88	0.79	0.72	0.66	0.56	0.49	0.43	
7+8				1.19	1.12	1.06	1.00	0.89	0.81	0.74	0.68	0.58	0.51	0.46	0.41
9+10			1.22	1.15	1.10	1.05	1.00	0.90	0.82	0.76	0.70	0.61	0.54	0.48	0.44
11+12			1.18	1.13	1.08	1.04	1.00	0.91	0.84	0.78	0.73	0.64	0.57	0.51	0.47
13+14		1.24	1.15	1.11	1.07	1.03	1.00	0.92	0.86	0.80	0.75	0.67	0.60	0.55	0.50
15+16		1.20	1.12	1.09	1.06	1.03	1.00	0.93	0.87	0.82	0.77	0.69	0.63	0.58	0.53
17+18	1.25	1.17	1.11	1.08	1.05	1.03	1.00	0.94	0.88	0.84	0.79	0.72	0.66	0.60	0.56

1)表中数值为最小值, 在 $f1 \geq 1.2$ 时可用满足要求。
如果给出了力的作用角和旋转方向, 则在绝大多数情况下可以承受较大的附加力。
请与我们联系,
在必要时可以采用一个加强型输出轴 (V)。

2) 敬请垂询

3) 地脚螺栓的最低性能等级为8.8。
基础必须干燥, 不得有油脂。

1) Values in tables are minimum values. They are valid for $f1 \geq 1.2$. If the angle of application of force and the direction of rotation are given, significantly higher additional forces can mostly be allowed.
Please consult us.
If necessary, a reinforced output shaft (V) can be used.
2) On request
3) Use foundation bolts of min property class 8.8 foundation must be dry and grease-free.

敬请垂询

-输入轴 d_1 上允许的附加径向力。
-双出轴实心轴上允许的附加径向力 (设计型式E、F和I)。
-19-26号齿轮箱上允许的附加径向力。

On request

-Permissible additional radial forces on input shaft d_1 .
-Permissible additional radial forces on solid output shafts on both sides (assemblies E, F and I).
-Permissible additional radial forces for gear unit sizes 19-26

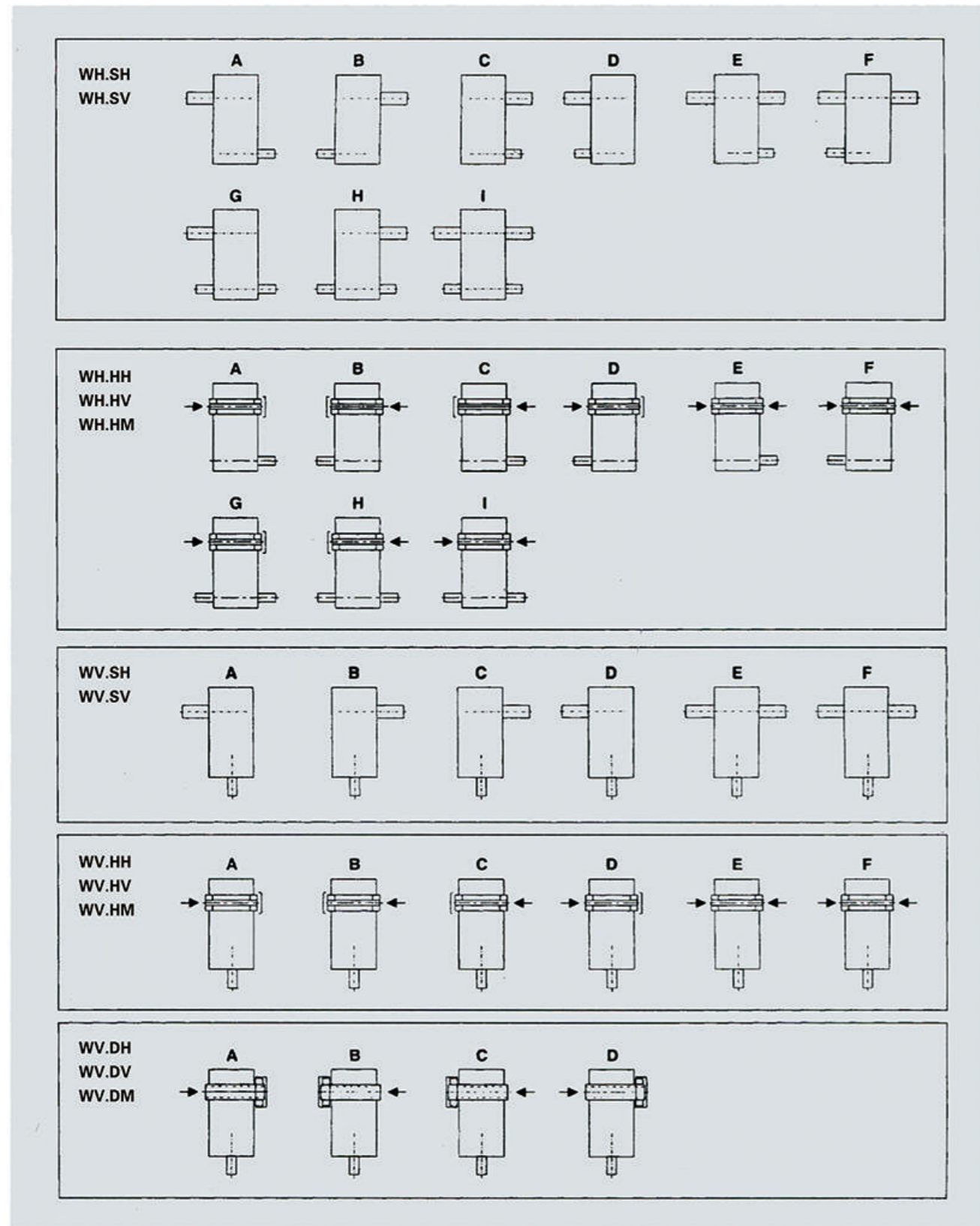

→ 箭头表示工作机驱动轴插入方向

the arrow indicates the direction of insertion of the driven machine shaft

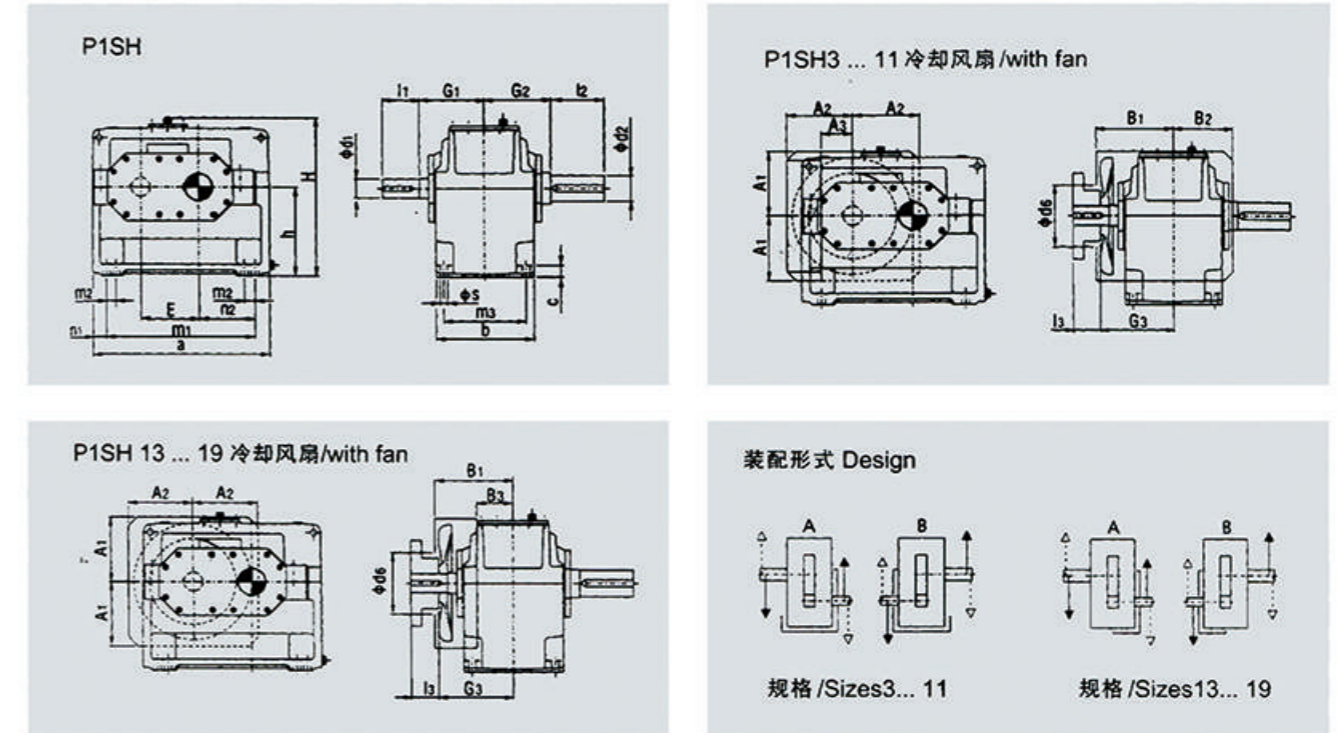

规格 Size	in=1.25-2.8			in=1.6-2.8			in=2-2.8			in=3.15-4			in=4.5-5.6			0 _a	A ₁	A ₂	A ₃	b	B ₁	B ₂
	d ₁	l ₁	l ₃	d ₁	l ₁	l ₃	d ₁	l ₁	l ₃	d ₁	l ₁	l ₃	d ₁	l ₁	l ₃							
3	60m6	125	105							45m6	100	80	32m6	80	60	420	150	145	80	200	205	130
5	85m6	160	130							60m6	135	105	50m6	110	80	580	255	215	115	285	255	185
7	100m6	200	165							75m6	140	105	60m6	140	105	690	255	250	120	375	300	230
9	110m6	200	165							90m6	165	130	75m6	140	105	805	300	265	140	425	330	265
11				130n6	240	205				110n6	205	170	90m6	170	135	960	360	330	190	515	375	320
13				150n6	245	200				130n6	245	200	100m6	210	165	1100	415	350	-	580	430	-
15							180n6	290	240	150n6	250	200	125n6	250	200	1295	500	430	-	545	430	-
17							200n6	330	280	170n6	290	240	140n6	250	200	1410	550	430	-	615	470	-
19							220n6	340	290	190n6	340	340	160n6	300	250	1590	630	475	-	690	510	-

规格 Size	B ₃	C	d ₂	d ₆	E	G ₁	G ₂	G ₃	h ⁻¹	H	l ₂	m ₁	m ₂	m ₃	n ₁	n ₂	s	润滑油oil(l)		重量 weight (kg) ^②
																		(1) [*]	(2) [*]	
3	-	28	60m6	130	130	170	170	190	200	375	125	310	-	160	55	110	19	7	5.2	128
5	-	35	85m6	190	185	210	210	240	290	525	160	440	-	240	70	160	24	22	18	302
7	-	45	105m6	245	225	250	250	285	350	625	200	540	-	315	75	195	28	42	34	547
9	-	50	125n6	280	265	280	270	315	420	735	210	625	-	350	90	225	35	68	57	862
11	-	60	150n6	350	320	325	320	360	500	875	240	770	-	440	95	280	35	120	100	1515
13	150	70	180n6	350	370	365	360	410	580	1020	310	870	-	490	115	315	42	175	155	2395
15	120	80	220n6	450	442	360	360	410	600	1115	350	1025	-	450	135	370	48	190	156	3200
17	150	80	240n6	445	490	400	400	450	670	1235	400	1170	130	530	120	425	42	270	225	4250
19	190	90	270n6	445	555	440	440	490	760	1395	450	1290	150	590	150	465	48	390	330	5800

(1)*轴封; (2)*迷宫式密封。

(1)*Shaft seal; (2)*Labyrinth seal.



两级传动
卧式安装
类型 WH2.H
规格 4-12

Two stage
Horizontal
Type WH2.H
Sizes 4-12

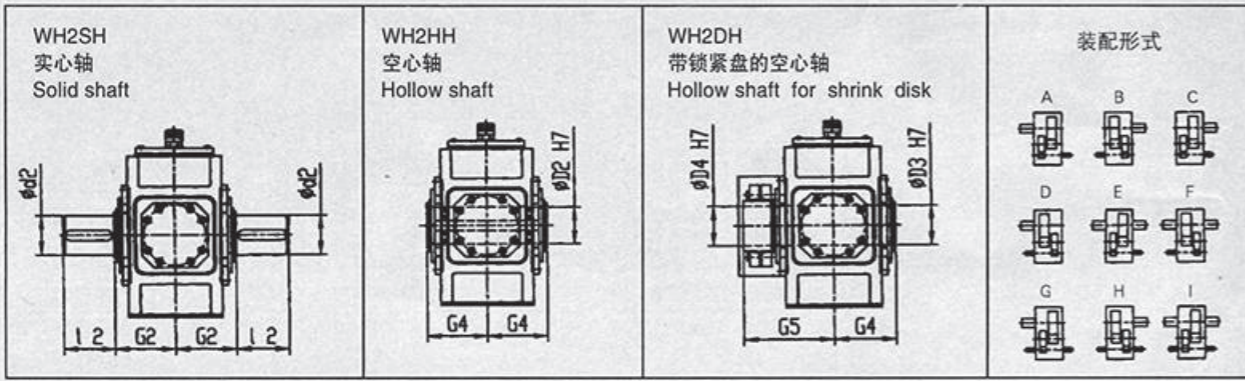
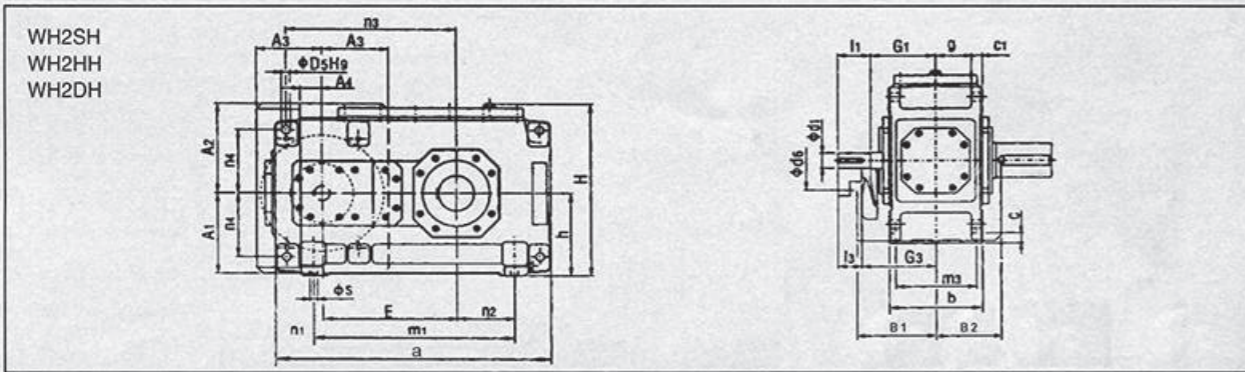

规格 Size	iN=6.3-11.2			iN=8-14			iN=12.5-22.4			iN=16-28			a	A1	A2	A3	A4	b	B1	B2	c	c1	d2	d6	D2	D3
	d1	l1	l3	d1	l1	l3	d1	l1	l3	d1	l1	l3														
4	45m6	100	80				32m6	80	60				565	195	225	150	30	215	205	158	28	30±1	80m6	136	80	85
5	50m6	100	80				38m6	80	60				640	225	260	175	55	255	230	178	28	30±1	100m6	150	95	100
6				50m6	100	80				38m6	80	60	720	225	260	175	55	255	230	178	28	30±1	110n6	150	105	110
7	60m6	135	105				50m6	110	80				785	272	305	210	70	300	255	210	35	36±1	120n6	200	115	120
8				60m6	135	105				50m6	110	80	890	272	305	210	70	300	255	210	35	36±1	130n6	200	125	130
9	75m6	140	110				60m6	140	110				925	312	355	240	100	370	285	245	40	45±1.5	140n6	200	135	145
10				75m6	140	110				60m6	140	110	1025	312	355	240	100	370	285	245	40	45±1.5	160n6	200	150	155
11	90m6	165	130				70m6	140					1105	372	420	285	135	430	325	285	50	54±1.5	170n6	210	165	170
12				90m6	165	130				70m6	140	105	1260	372	475	285	135	430	325	285	50	54±1.5	180n6	210	180	185

规格 Size	D4	D5	E	g	G1	G2	G3	G4	G5	h ⁻¹	H	l ₂	m1	m3	n1	n2	n3	n4	s	润滑油(l)		重量 weight t
																				(1)*	(2)*	
4	85	24	270	77.5	170	140	190	140	205	200	415	170	355	180	105	85	345	150	19	10	7	190
5	100	24	315	97.5	195	165	215	165	240	230	482	210	430	220	105	100	405	180	19	15	11	300
6	110	24	350	97.5	195	165	215	165	240	230	482	210	510	220	105	145	440	180	19	16	12	355
7	120	28	385	114	210	195	240	195	280	280	572	210	545	260	120	130	550	215	24	27	21	505
8	130	28	430	114	210	195	240	195	285	280	582	250	650	260	120	190	545	215	24	30	23	590
9	140	36	450	140	240	235	270	235	330	320	662	250	635	320	145	155	585	245	28	42	33	830
10	150	36	500	140	240	235	270	235	350	320	662	300	735	320	145	205	635	245	28	45	34	960
11	165	40	545	161	275	270	310	270	400	380	782	300	775	370	165	180	710	300	35	71	58	1335
12	180	40	615	161	275	270	310	270	405	380	790	300	930	370	165	265	780	300	35	76	60	1615

(1)*轴封; (2)*迷宫式密封。

(1)*Shaft seal; (2)*Labyrinth seal.



两级传动
卧式安装
类型 WH2.H, WH2.M
规格 13-26

Two stage
Horizontal
Type WH2.H, WH2.M
Sizes 13-26

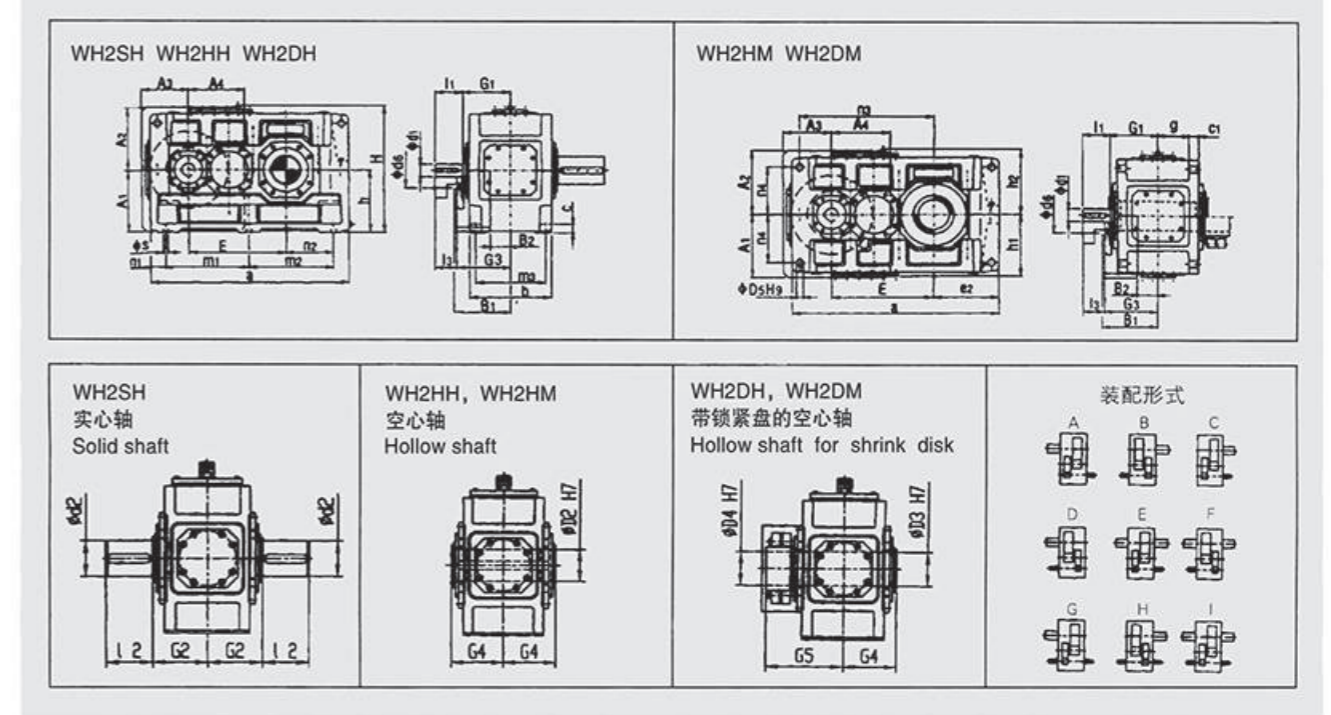

规格 Size	iN=6.3-11.2			iN=7.1-12.5			iN=8-14			iN=12.5-20			iN=14-22.4			iN=16-25			a	A1	A2	A3	A4	b	B1	B2	c	c1	d2	d6	D2	D3
	d1	l1	l3	d1	l1	l3	d1	l1	l3	d1	l1	l3	d1	l1	l3	d1	l1	l3														
13	100m6	205	170							85m6	170	135							1290	430	460	330	365	550	385	135	60	61±2	200n6	250	190	195
14										100m6	205	170							1430	430	460	330	365	550	385	135	60	61±2	210n6	250	210	215
15	120m6	210	165							100m	210	165							1550	490	500	370	440	625	430	155	70	72±2	230n6	280	230	235
16				120n6	210	165													1640	490	500	370	440	625	430	155	70	72±2	240n6	280	240	245
17	125n6	245	200							110n6	210	165							1740	540	565	435	505	690	485	140	80	81±2	250n6	280	250	260
18				125n6	245	200							110n6	210	165				1860	540	565	435	505	690	485	140	80	81±2	270n6	280	275	285
19	150n6	245	200							120n6	210	165							2010	600	600	500	450	790	540	190	90	91±2	290n6	310	-	295
20				150n6	245	200							120n6	210	165				2130	600	600	500	450	790	540	190	90	91±2	300n6	310	-	315
21	170n6	290	240							140n6	250	200							2140	680	680	500	610	830	565	200	100	100±2	320n6	450	-	335
22				170n6	290	240							140n6	250	200				2250	680	680	500	610	830	565	200	100	100±2	340n6	450	-	345
23	190n6	330	280							150n6	250	200							2380	770	770	550	550	930	630	220	115	120±2	360n6	450	-	365
24				190n6	330	280							150n6	250	200				2510	770	770	550	550	930	630	220	115	120±2	380n6	450	-	385
25	200n6	340	290							170n6	300	250							2580	845	865	550	550	1045	670	240	130	120±2	400n6	450	-	405
26				200n6	340	290							170n6	300	250				2760	845	865	550	550	1045	670	240	130	120±2	420n6	450	-	435

规格 Size	D4	D5	e ₂	E	g	G1	G2	G3	G4	G5	h ⁻¹	h ₁	h ₂	H	l ₂	m1	m2	m3	n1	n2	n3	n4	s	润滑油(l)		重量 weight (kg)		
																								(1)*	(2)*			
13	190	48	405	635	211.5	330	335	365	335	480	440	450	460	900	350	545	545	475	100	305	835	340	35	135	120	110	2000	1880
14	210	48	475	705	211.5	330	335	365	335	480	440	450	460	900	350	545	685	475	100	375	905	340	35	140	130	115	2570	2430
15	230	55	485	762	238	365	380	410	380	550	500	490	500	1000	410	655	655	535	120	365	1005	375	42	210	190	160	3430	3240
16	240	55	530	808	238	365	380	410	380	550	500	490	500	1000	410	655	745	535	120	410	1050	375	42	215	200	165	3665	3465
17	250	55	525	860	259	420	415	465	415	600	550	555	560	1110	410	735	735	600	135	390	1145	425	42	290	260	230	4650	4420
18	280	55	585	920	259	420	415	465	415	600	550	555	560	1110	470	735	855	600	135	450	1205	425	42	300	270	240	5152	4870
19	285	65	590	997	299	475	465	520	465	670	620	615	620	1240	470	850	850	690	155	435	1345	475	48	320	-	300	6600	6300
20	310	65	650	1057	299	475	465	520	465	670	620	615	620	1240	500	850	970	690	155	495	1405	475	48	340	-	320	7500	7200
21	330	75	655	1067	310	495	490	545	490	715	700	685	690	1390	500	900	900	720	170	485	1400	520	56	320	-	350	8900	8400
22	340	75	710	1122	310	495	490	545	490	725	700	685	690	1390	550	900	1010	720	170	540	1455	520	56	340	-	370	9800	9200
23	360	80	730	1185	342	560	540	610	540	785	780	770	770	1550	590	1010	1010	810	180	550	1560	580	56	430	-	470	11600	11100
24	380	80	795	1250	342	560	540	610	540	805	780	770	770	1550	590	1010	1140	810	180	615	1625	580	56	450	-	500	13000	12300
25	400	90	790	1325	400	600	605	605	605	875	860	860	860	1720	650	1090	1090	910	200	590	1685	660	66	600	-	660	15500	14700
26	430	90	880	1415	400	600	605	650	605	900	860	860	860	1720	650	1090	1270	910	200	680	1775	660	66	640	-	700	1720	



三级传动
卧式安装
类型 WH3.H
规格 5-12

Three stage
Horizontal
Type WH3.H
Sizes 5-12

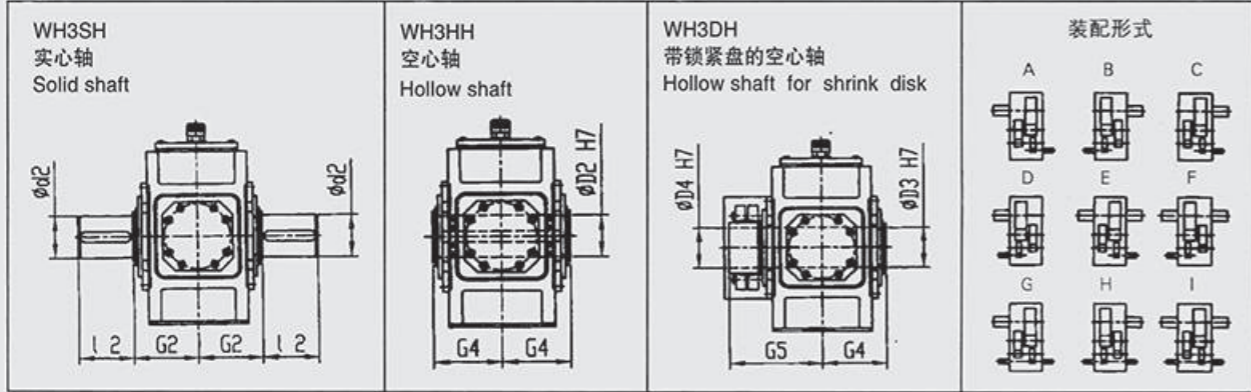
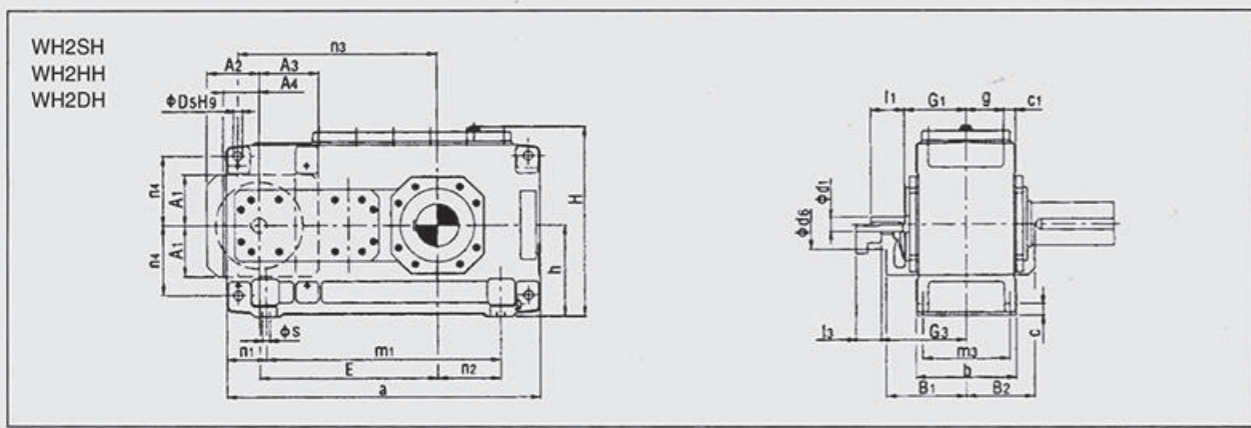

规格 Size	in=25-45			in=31.5-56			in=50-63			in=63-80			in=71-90			in=90-112			a	A ₄	A ₁	A ₂	A ₃	b	B ₁	B ₂	c ₁	c	d ₂
	d ₁	l ₁	l ₃	d ₁	l ₁	l ₃	d ₁	l ₁	l ₃	d ₁	l ₁	l ₃	d ₁	l ₁	l ₃	d ₁	l ₁	l ₃											
5	40m6	70	70				30m6	50	50				24k6	40	40				690	140	137	135	140	255	215	175	30±1	28	100m6
6				40m6	70	70				30m6	50	50				24k6	40	40	770	140	137	135	140	255	215	175	30±1	28	110n6
7	45m6	80	80				35m6	60	60				28m6	50	50				845	180	157	160	180	300	245	205	36±1	35	120n6
8				45m6	80	80				35m6	60	60				28m6	50	50	950	180	157	160	180	300	245	205	36±1	35	130n6
9	60m6	125	105				45m6	100	80				32m6	80	60				1000	205	182	190	205	370	295	240	45±1.5	40	140n6
10				60m6	125	105				45m6	100	80				32m6	80	60	1100	205	182	190	205	370	295	240	45±1.5	40	160n6
11	70m6	120	120				50m6	80	80				42m6	70	70				1200	255	218	220	255	430	325	280	54±1.5	50	170n6
12				70m6	120	120				50m6	80	80				42m6	70	70	1355	255	218	220	255	430	325	280	54±1.5	50	180n6

规格 Size	d ₆	D ₂	D ₃	D ₄	D ₅	E	g	G ₁	G ₂	G ₃	G ₄	G ₅	h ⁻¹	H	l ₂	m ₁	m ₃	n ₁	n ₂	n ₃	n ₄	s	润滑油 oil(l)	重量 weight (kg)
5	60	95	100	100	24	405	97.5	160	165	220	165	240	230	482	210	480	220	105	100	455	180	19	16	320
6	60	105	110	110	24	440	97.5	160	165	220	165	240	230	482	210	560	220	105	145	490	180	19	18	365
7	75	115	120	120	28	495	114	185	195	250	195	280	280	572	210	605	260	120	130	560	215	24	29	540
8	75	125	130	130	28	540	114	185	195	250	195	285	280	582	250	710	260	120	190	605	215	24	32	625
9	90	135	145	140	36	580	140	230	235	300	235	330	320	662	250	710	320	145	155	660	245	28	48	875
10	90	150	155	150	36	630	140	230	235	300	235	350	320	662	300	810	320	145	205	710	245	28	49	1020
11	100	165	170	165	40	705	161	255	270	330	270	400	380	782	300	870	370	165	180	805	300	35	85	1400
12	100	180	185	180	40	775	161	255	270	330	270	405	380	790	300	1025	370	165	265	875	300	35	90	1675



三级传动
卧式安装
类型 WH3.H, WH3.M
规格 13-26

Three stage
Horizontal
Type WH3.H, WH3.M
Sizes 13-26

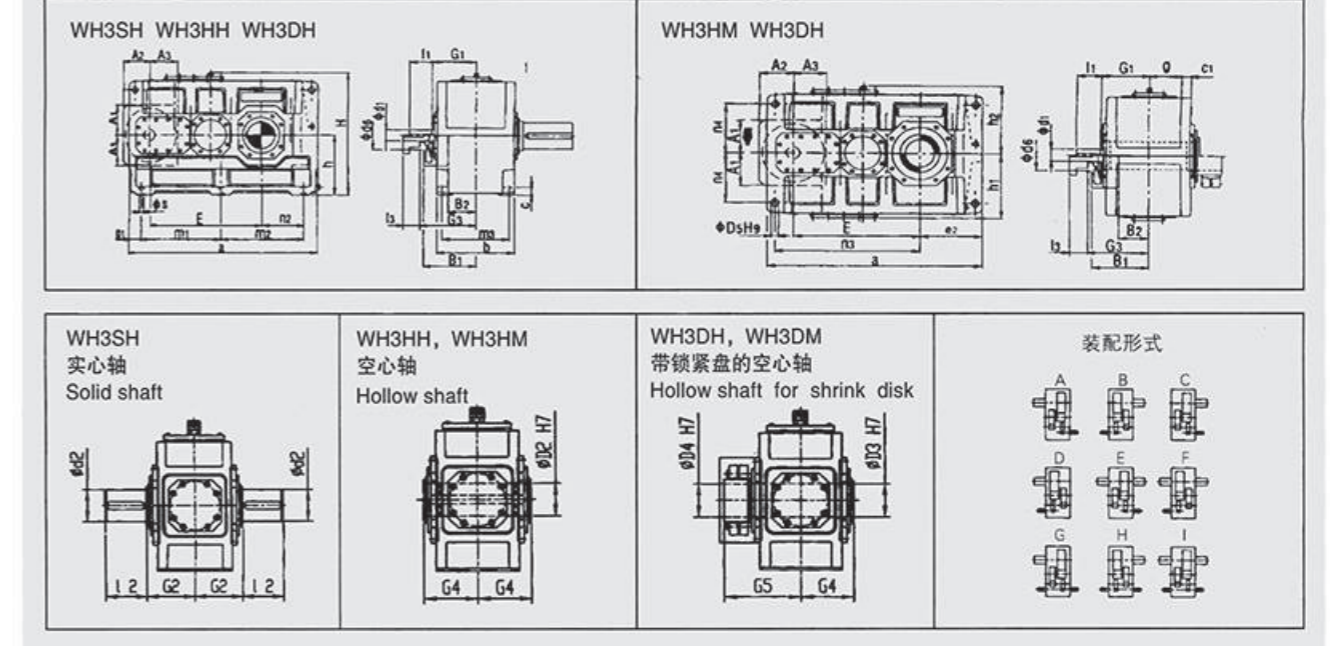

规格 Size	in=22.4-45			in=25-50			in=50-63			in=56-71			in=71-90			in=80-100			a	A ₁	A ₂	A ₃	b	B ₁	B ₂	c	c ₁	d ₂	d ₅	D ₂	D ₃	
	d ₁	l ₁	l ₃	d ₁	l ₁	l ₃	d ₁	l ₁	l ₃	d ₁	l ₁	l ₃	d ₁	l ₁	l ₃	d ₁	l ₁	l ₃														
13	85m6	160	165				60m6	135	105				50m6	110	80				1395	225	225	212	550	380	195	60	61±2	200n6	120	190	195	
14				in=28-56			in=63-80			in=90-112						1535	225	225	212	550	380	195	60	61±2	210n6	120	210	215				
15	100m6	200	165				75m6	140	105				60m6	140	105				1680	270	265	252	625	415	205	70	72±2	230n6	150	230	235	
16				100m6	200	165				75m6	140	105				60m6	140	105	1770	270	265	252	625	415	205	70	72±2	240n6	150	240	245	
17	100m6	200	165				75m6	140	105				60m6	140	105				1770	270	265	252	690	455	235	80	81±2	250n6	150	250	260	
18				100m6	200	165				75m6	140	105				60m6	140	105	1890	270	265	252	690	455	235	80	81±2	270n6	150	275	285	
19	110m6	200	*				90m6	165	*				75m6	140	*				2030	*	*	*	790	*	*	90	91±2	290n6	*	-	295	
20				110m6	200	*				90m6	165	*				75m6	140	*		2150	*	*	*	790	*	*	90	91±2	300n6	*	-	315
21	130m6	240	*				110n6	205	*				90m6	170	*				2340	*	*	*	830	*	*	100	100±2	320n6	*	-	335	
22				130m6	240	*				110n6	205	*				90m6	170	*		2450	*	*	*	830	*	*	100	100±2	340n6	*	-	345
23	130m6	240	-				110n6	205	-				90m6	170	-				2530	-	-	-	930	-	-	115	120±2	360n6	-	-	365	
24				130m6	240	-				110n6	205	-				90m6	170	-		2660	-	-	-	930	-	-	115	120±2	380n6	-	-	385
25	150m6	245	-				130n6	245	-				150m6	210	-				2830	-	-	-	1045	-	-	130	120±2	400n6	-	-	405	
26				150m6	245	-				130n6	245	-				100m6	210	-		3010	-	-	-	1045	-	-	130	120±2	420n6	-	-	435

规格 Size	D ₄	D ₅	e ₂	E	g	G ₁	G ₂	G ₃	G ₄	G ₅	h ⁻¹	h ₁	h ₂	H	l ₂	m ₁	m ₂	m ₃	n ₁	n ₂	n ₃	n ₄	s	润滑油oil(l)				重量 weight (kg)
																								H _{3.H}	H _{3.M}	H _{2.H}	H _{2.M}	
13	190	48	405	820	211.5	310	335	385	335	480	440	450	460	900	350	597.5	597.5	475	100	305	940	340	35	160	125	2295	2155	
14	210	48	475	890	211.5	310	335	385	335	480	440	450	460	900	350	597.5	597.5	475	100	375	1010	340	35	165	130	2625	2490	
15	230	55	485	987	238	350	380	420	380	550	500	490	500	1000	410	720	720	535	120	365	1135	375	42	235	190	3475	3260	
16	240	55	530	1033	238	350	380	420	380	550	500	490	500	1000	410	720	810	535	120	410	1180	375	42	245	195	3875	3625	
17	250	55	525	1035	259	380	415	450	415	600	550	555	560	1100	410	750	750	600	135	390	1175	425	42	305	240	4560	4250	
18	280	55	585	1095	259	380	415	450	415	600	550	555	560	1100	470	750	870	600	135	450	1235	425	42	315	250	5030	4740	
19	285	65	590	1190	299	430	465	*	465	670	620	615	620	1240	470	860	860	690	155	435	1365	475	48	320	390	6700	6200	
20	310	65	650	1250	299	430	465	*	465	670	620	615	620	1240	500	860	980	690	155	495	1425	475	48	450	415	8100	7600	
21	330	75	655	1387	310	470	490	*	490	715	700	685	690	1390	500	1000	1000	720	170									



四级传动
卧式安装
类型 WH4.H
规格 7-12

Four stage
Horizontal
Type WH4.H
Sizes 7-12

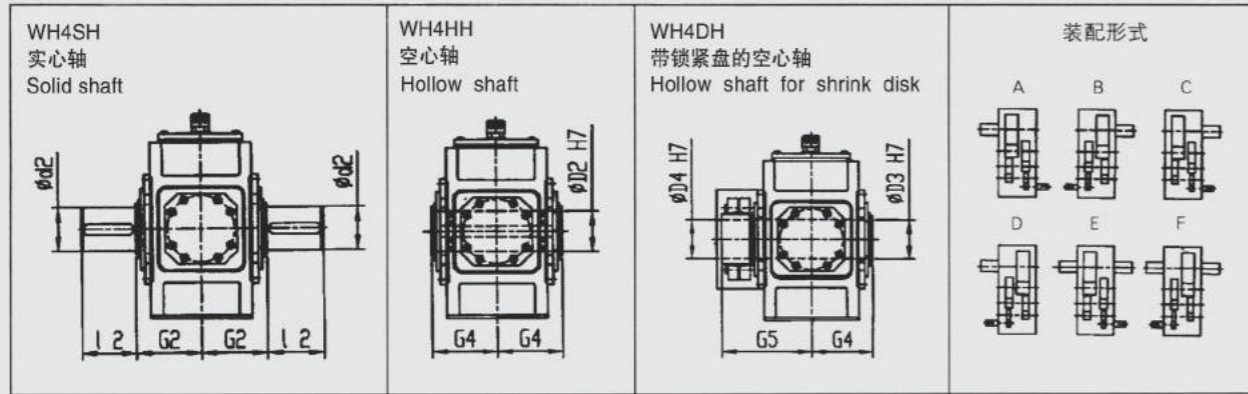
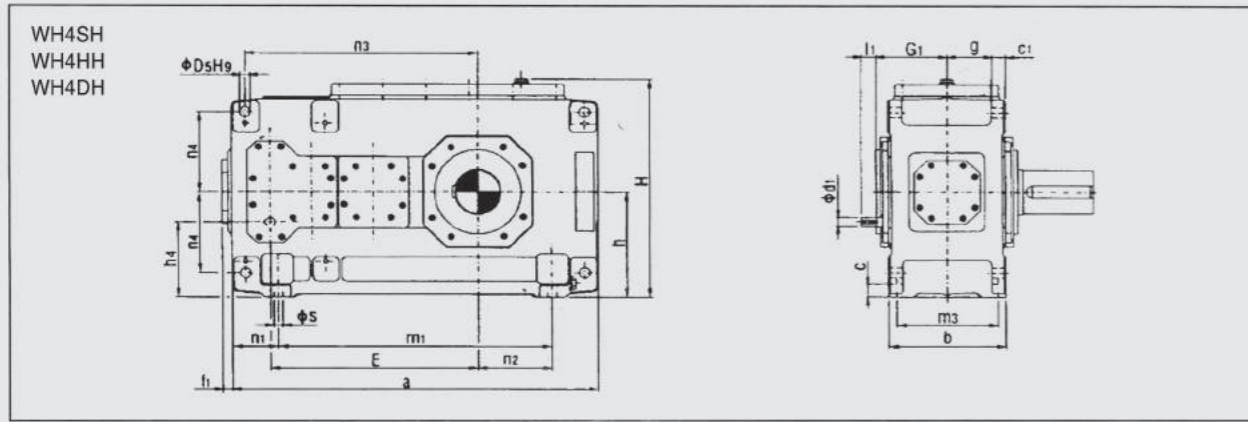

规格 Size	in=100-180		in=125-224		in=200-355		in=250-450		a	b	c	c ₁	d ₂	D ₂	D ₃	D ₄	D ₅	e ₂	E	E ₁
	d ₁	l ₁	d ₁	l ₁	d ₁	l ₁	d ₁	l ₁												
7	30m6	50			24k6	40			845	300	35	36±1	120n6	115	120	120	28	495		
8			30m6	50			24k6	40	950	330	35	36±1	130n6	125	130	130	28	540		
9	35m6	60			28m6	50			1000	370	40	45±1.5	140n6	135	145	140	36	580		
10			35m6	60			28m6	50	1100	370	40	45±1.5	160n6	150	155	150	36	630		
11	45m6	100			32m6	80			1200	430	50	54±1.5	170n6	165	170	165	40	705		
12			45m6	100			32m6	80	1355	430	50	54±1.5	180n6	180	185	180	40	775		

规格 Size	f ₁	g	G ₁	G ₂	G ₄	G ₅	h ⁻¹	h ₄	H	l ₂	m ₁	m ₃	n ₁	n ₂	n ₃	n ₄	s	润滑油 oil(l)	重量 weight (kg)
7	37	114	180	195	195	280	280	200	572	210	605	260	120	130	560	215	24	25	550
8	37	114	180	195	195	285	280	200	582	250	710	260	120	190	605	215	24	27	645
9	43	140	215	235	235	330	320	230	662	250	710	320	145	155	660	245	28	48	875
10	43	140	215	235	235	350	320	230	662	300	810	320	145	205	710	245	28	50	1010
11	47	161	250	270	270	400	380	270	782	300	870	370	165	180	805	300	35	80	1460
12	47	161	250	270	270	405	380	270	790	300	1025	370	165	265	875	300	35	87	1725



四级传动
卧式安装
类型 WH4.H, WH4.M
规格 13-26

Four stage
Horizontal
Type WH4.H, WH4.M
Sizes 13-26

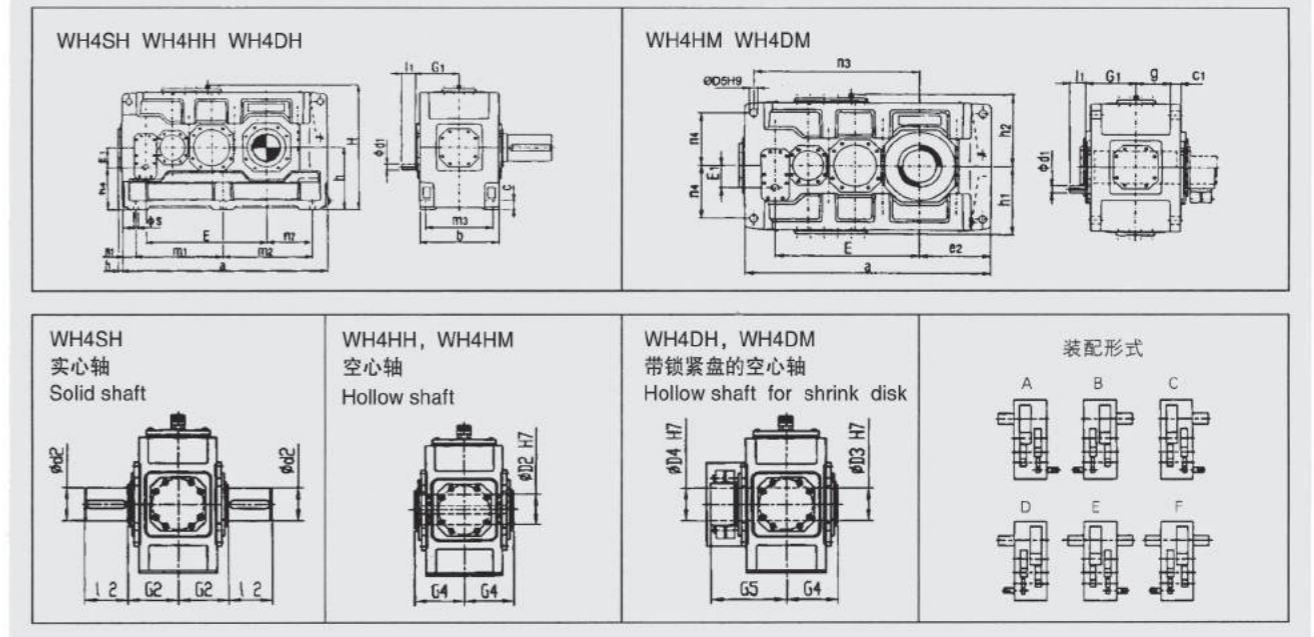

规格 Size	in=100-180		in=112-200		in=125-224		in=200-355		in=224-400		in=250-450		a	b	c	c ₁	d ₂	D ₂	D ₃	D ₄	D ₅	e ₂	E	E ₁	
	d ₁	l ₁	d ₁	l ₁	d ₁	l ₁	d ₁	l ₁	d ₁	l ₁	d ₁	l ₁													
13	50m6	100					38m6	80					1395	550	60	61±2	200n6	190	195	190	48	405	820	130	
14					50m6	100						38m6	80	1535	550	60	61±2	210n6	210	215	210	48	475	890	130
15	60m6	135					50m6	110					1680	625	70	72±2	230n6	230	235	230	55	485	987	160	
16			60m6	135					50m6	110			1770	625	70	72±2	240n6	240	245	240	55	530	1033	160	
17	60m6	105					50m6	80					1770	690	80	81±2	250n6	250	260	250	55	525	1035	160	
18			60m6	105					50m6	80			1890	690	80	81±2	270n6	275	285	280	55	585	1095	160	
19	75m6	105					60m6	105					2030	790	90	91±2	290n6	-	295	285	65	590	1190	185	
20			75m6	105					60m6	105			2150	790	90	91±2	300n6	-	315	310	65	650	1250	185	
21	90m6	165					70m6	140					2340	830	100	100±2	320n6	-	335	330	75	655	1387	225	
22			90m6	165					70m6	140			2450	830	100	100±2	340n6	-	345	340	75	710	1442	225	
23	90m6	130					70m6	105					2530	930	115	120±2	360n6	-	365	360	80	730	1505	225	
24			90m6	130					70m6	105			2660	930	115	120±2	380n6	-	385	380	80	795	1570	225	
25	100m6	205					850m6	170					2830	1045	130	120±2	400n6	-	405	400	90	790	1695	265	
26			100m6	205					85m6	170			3010	1045	130	120±2	420n6	-	435	430	90	880	1785	265	

规格 Size	f ₁	g	G ₁	G ₂	G ₄	G ₅	h ⁻¹	h ₁	h ₂	h ₄	H	l ₂	m ₁	m ₂	m ₃	n ₁	n ₂	n ₃	n ₄	s	润滑油oil(l)				重量 weight (kg)
																					H3.H	H3.M	H2.H	H2.M	
13	47	211.5	305	335	335	480	440	450	460	310	900	350	597.5	597.5	475	100	305	940	340	35	130	120	2390	2270	
14	47	211.5	305	335	335	480	440	450	460	310	900	350	597.5	737.5	475	100	375	1010	340	35	140	125	2730	2600	
15	56	238	345	380	380	550	500	490	500	340	1000	410	720	720	535	120	365	1135	375	42	230	170	3635	3440	
16	56	238	345	380	380	550	500	490	500	340	1000	410	720	810	535	120	410	1180	375	42	235	175	3965	3740	
17	53	259	380	415	415	600	550	555	560	390	1100	410	750	750	600	135	390	1175	425	42	290	225	4680	4445	
18	53	259	380	415	415	600	550	555	560	390	1100	470	750	870	600	135	450	1235	425	42	305	230	5185	4915	
19	53	299	440	465		670	620	615	620	435	1240	470	860	860	690	155	435	1365	475	48	430	310	6800	6300	
20	53	299	440	465		670	620	615	620	435	1240	500	860	980	690	155	495	1425	475	48	380	330	8200	7700	
21	62	310	460	490		715	700	685	690	475	1390	500	1000	1000	720	170	485	1600	520	56	395	430	9200	8600	
22	62	310	460	490		725	700	685	690	475	1390	550	1000	1110	720	170	540	1655	520	56	420	450	9900	9400	
23	35	342	505	540		785	780	770	770	555	1570	590	1085	1085	810	180	550	1725	580	56	520	500	11600	10700	
24	35	342	505	540		805	780	770	770	555	1570	590	1085	1215	810	180	615	1790	580	56	550	600	13500	12600	
25	65	400	565	605		875	860	860	860	595	1720	650	1215	1215	910	200	590	1965	660	66	735	800	16100	15200	
26	65	400	565	605		900	860	860	860	595	1720	650	1215	1395	910	200	680	2055	660	66	780	850	17600	16500	

两级传动
卧式安装
类型 WV2.H
规格 4-12

Two stage
Horizontal
Type WV2.H
Sizes 4-12

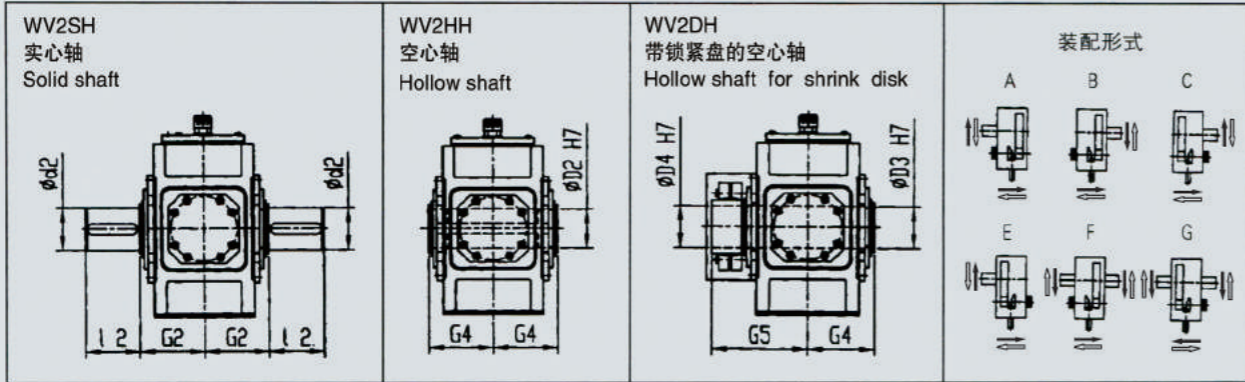
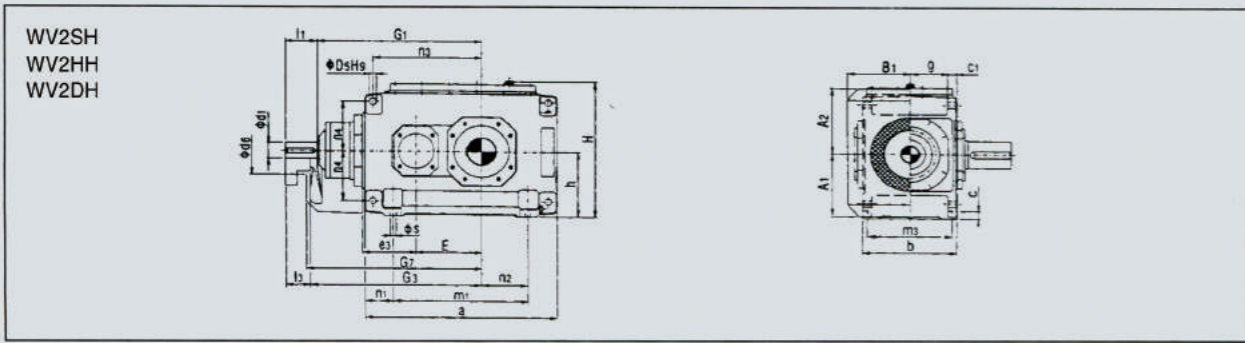

规格 Size	in=5-11.2			in=6.3-14			a	A1	A2	b	B1	c	c1	d2	d6	D2	D3	D4	D5	e3	E
	d1	l1	l3	d1	l1	l3															
4	45m6	100	80				505	195	200	270	188	28	30±1	80m6	150	80	85	85	24	160	160
5	55m6	110	80				565	220	235	320	215	28	30±1	100m6	160	95	100	100	24	185	185
6				55m6	110	80	645	220	235	320	215	28	30±1	110n6	160	105	110	110	24	185	220
7	70m6	135	105				690	270	285	380	250	35	36±1	120n6	210	115	120	120	28	225	225
8				70m6	135	105	795	270	285	380	250	35	36±1	130n6	210	125	130	130	28	225	270
9	80m6	165	130				820	310	325	440	270	40	48±1.5	140n6	195	135	145	140	36	265	265
10				80m6	165	130	920	310	325	440	270	40	48±1.5	160n6	195	150	155	150	36	265	315
11	90m6	165	130				975	370	385	530	328	50	54±1.5	170n6	210	165	170	165	40	320	320
12				90m6	165	130	1130	370	385	530	328	50	54±1.5	180n6	210	180	185	180	40	320	390

规格 Size	g	G1	G2	G3	G4	G5	G7	h ⁻¹	H	l2	m1	m3	n1	n2	n3	n4	s	润滑油oil(D)		重量 weight (kg)
																		(1)*	(2)*	
4	105	465	170	485	170	235	495	200	415	170	295	235	105	85	285	150	19	10		235
5	130	535	200	565	200	275	575	230	482	210	355	285	105	100	330	180	19	16		360
6	130	570	200	600	200	275	610	230	482	210	435	285	105	145	365	180	19	19		410
7	154	640	235	670	235	320	685	280	582	210	450	340	120	130	405	215	24	31		615
8	154	685	235	715	235	325	730	280	582	250	555	340	120	190	450	215	24	34		700
9	172	755	270	790	270	365	805	320	662	250	530	390	145	155	480	245	28	48		1000
10	172	805	270	840	270	385	855	320	662	300	630	390	145	205	530	245	28	50		1155
11	211	925	320	960	320	450	980	380	790	300	645	470	165	180	580	300	35	80		1640
12	211	995	320	1030	320	455	1050	380	790	300	800	470	165	265	650	300	35	95		1910

(1)*轴封; (2)*迷宫式密封。

(1)*Shaft seal; (2)*Labyrinth seal.

两级传动
卧式安装
类型 WV2.H, WV2.M
规格 13-18

Two stage
Horizontal
Type WV2.H, WV2.M
Sizes 13-18

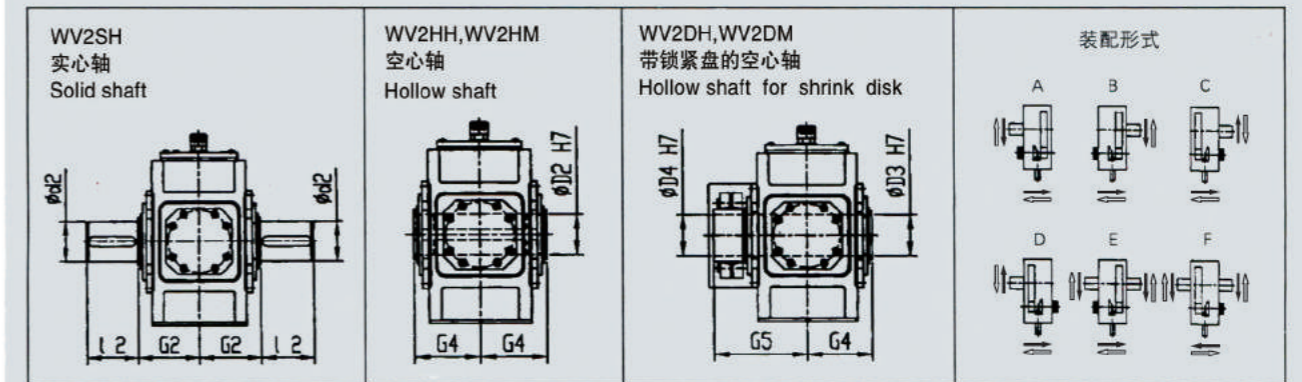
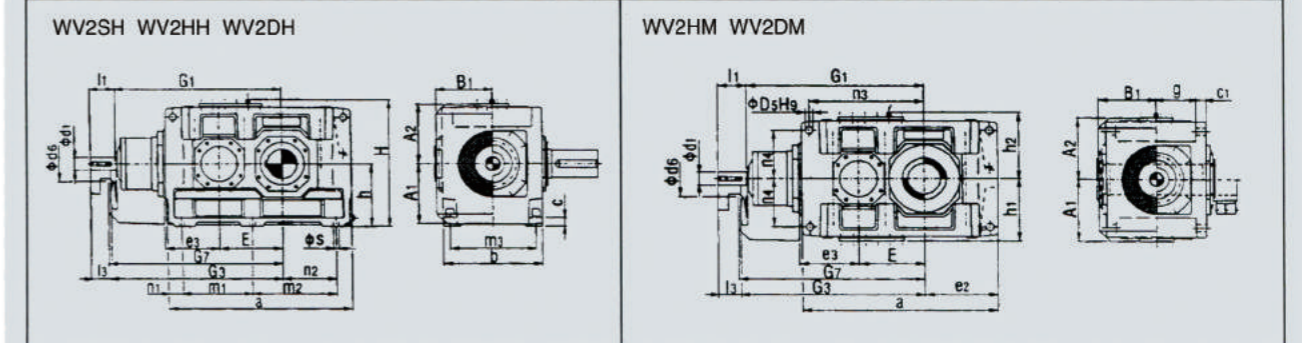

规格 Size	in=5-11.2			in=5.6-11.2			in=5-12.5			in=6.3-14			in=7.1-12.5			a	A1	A2	b	B1	c	c1	d2	d6	D2	D3	D4	D5	e2	e3			
	d1	l1	l3	d1	l1	l3	d1	l1	l3	d1	l1	l3	d1	l1	l3																		
13	110n6	205	165													1130	430	450	655	375	60	61±2	200n6	245	-	-	-	48	405	380			
14																1270	430	450	655	375	60	61±2	210n6	245	210	215	210	48	475	380			
15	130n6	245	200													1350	490	495	765	435	70	72±2	230n6	280	-	-	-	55	485	450			
16																1440	490	495	765	435	70	72±2	240n6	280	240	245	240	55	530	450			
17																1490	540	555	885	505	80	81±2	250n6	380	-	-	-	65	525	510			
18																150n6	245	200	1610	540	555	885	505	80	81±2	270n6	380	275	285	280	65	585	510

规格 Size	E	g	G1	G2	G3	G4	G5	G7	h ⁻¹	h1	h2	H	l2	m1	m2	m3	n1	n2	n3	n4	s	润滑油oil(D)		重量 weight (kg)		
																						(1)*	(2)*			
13	370	264	1070	390	1110	-	-	1130	440	450	460	900	350	465	465	580	100	305	675	340	35	140		120	2450	2350
14	440	264	1140	390	1180	390	535	1200	440	450	460	900	350	465	605	580	100	375	745	340	35	155		130	2845	2725
15	442	308	1277	460	1322	-	-	1340	500	490	500	1000	410	555	555	670	120	365	805	375	42	220		180	3990	3795
16	488	308	1323	460	1368	450	620	1385	500	490	500	1000	410	555	645	670	120	410	850	375	42	230		190	4345	4160
17	490	356	1435	540	1480	-	-	1500	550	555	560	1110	410	610	610	780	135	390	895	420	48	320		260	5620	5320
18	550	356	1495	540	1540	510	700	1560	550	555	560	1110	470	610	730	780	135	450	955	420	48	335		275	6150	5860

(1)*轴封; (2)*迷宫式密封。

(1)*Shaft seal; (2)*Labyrinth seal.



三级传动
卧式安装
类型 WV3.H
规格 4-12

Three stage
Horizontal
Type WV3.H
Sizes 4-12

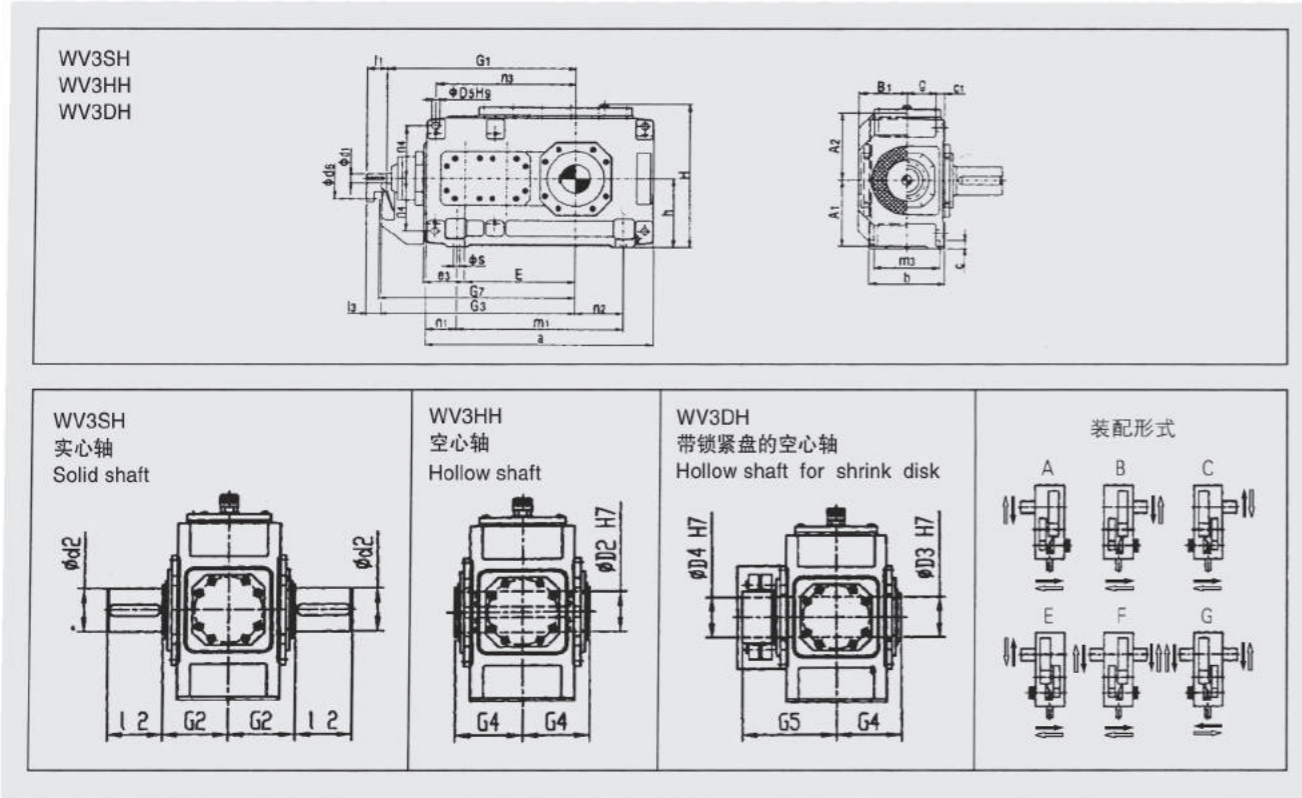

规格 Size	iN=12.5-45			iN=16-56			iN=50-71			iN=63-90			a	A ₁	A ₂	b	B ₁	c	c ₁	d ₂	d ₆	D ₂	D ₃	D ₄
	d ₁	l ₁	l ₃	d ₁	l ₁	l ₃	d ₁	l ₁	l ₃	d ₁	l ₁	l ₃												
4	30m6	70	50				25m6	60	40				565	195	200	215	143	28	30±1	80m6	110	80	85	85
5	35m6	80	60				28m6	60	40				640	220	235	255	188	28	30±1	100m6	130	95	100	100
6				35m6	80	60				28m6	60	40	720	220	235	255	188	28	30±1	110n6	130	105	110	110
7	45m6	100	80				35m6	80	60				785	275	285	300	193	35	36±1	120n6	165	115	120	120
8				45m6	100	80				35m6	80	60	890	275	285	300	193	35	36±1	130n6	165	125	130	130
9	55m6	110	80				40m6	100	70				925	315	325	370	231	40	45±1.5	140n6	175	135	145	140
10				55m6	110	80				40m6	100	70	1025	315	325	370	231	40	45±1.5	160n6	175	150	165	150
11	70m6	135	105				50m6	110	80				1105	370	385	430	263	50	54±1.5	170n6	190	165	170	165
12				70m6	135	105				50m6	110	80	1260	370	385	430	263	50	54±1.5	180n6	190	180	185	180

规格 Size	D ₅	e ₃	E	g	G ₁	G ₂	G ₃	G ₄	G ₅	G ₇	h ⁻¹	h ₅	H	l ₂	m ₁	m ₃	n ₁	n ₂	n ₃	n ₄	s	润滑油 oil(l)	重量 weight (kg)
4	24	110	270	77.5	500	140	520	140	205	530	200	100	415	170	355	180	105	85	345	150	19	9	210
5	24	130	315	97.5	575	165	595	165	240	605	230	130	482	210	430	220	105	100	405	180	19	15	325
6	24	130	350	97.5	610	165	630	165	240	640	230	130	482	210	510	220	105	145	440	180	19	16	380
7	28	180	385	114	690	195	710	195	280	720	280	170	572	210	545	260	120	130	500	215	24	27	550
8	28	180	430	114	735	195	755	195	285	765	280	160	582	250	650	260	120	190	545	215	24	30	635
9	36	185	450	140	800	235	830	235	330	845	320	175	662	250	635	320	145	155	585	245	28	42	890
10	36	185	500	140	850	235	880	235	350	895	320	175	662	300	735	320	145	205	635	245	28	45	1020
11	40	225	545	161	960	270	990	270	400	1010	380	220	782	300	775	370	165	180	710	300	35	71	1455
12	40	225	615	161	1030	270	1060	270	405	1080	380	210	790	300	930	370	165	265	780	300	35	76	1730



三级传动
卧式安装
类型 WV3.H, WV3.M
规格 13-26

Three stage
Horizontal
Type WV3.H, WV3.M
Sizes 13-26

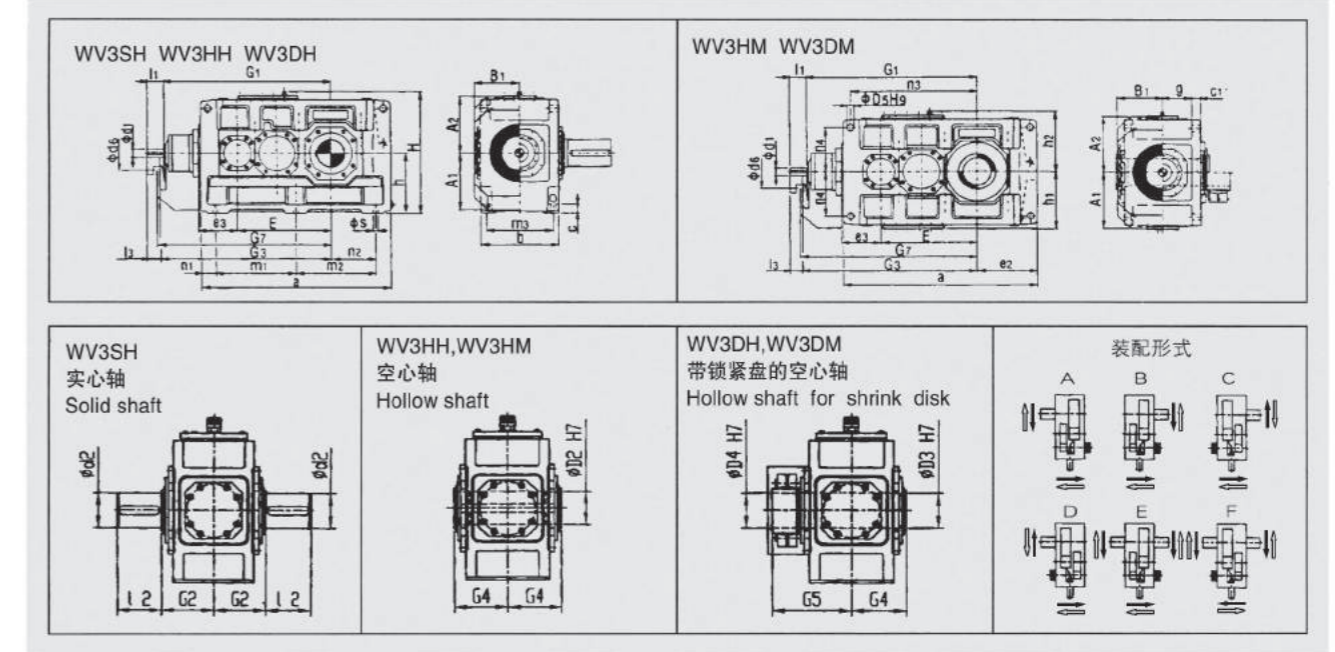

规格 Size	iN=12.5-45			iN=14-50			iN=16-56			iN=50-71			iN=56-80			iN=63-90			a	A ₁	A ₂	b	B ₁	c	c ₁	d ₂	d ₆	D ₂	D ₃	D ₄
	d ₁	l ₁	l ₃	d ₁	l ₁	l ₃	d ₁	l ₁	l ₃	d ₁	l ₁	l ₃	d ₁	l ₁	l ₃	d ₁	l ₁	l ₃												
13	80m6	165	130						60m6	140	105								1290	425	435	550	325	60	61±2	200n6	210	190	195	190
14							80n6	165	130							60m6	140	105	1430	425	435	550	325	60	61±2	210n6	210	210	215	210
15	90m6	165	130						70m6	140	105								1550	485	520	625	365	70	72±2	230n6	210	230	235	230
16				90m6	165	130									70m6	140	105		1640	485	520	625	365	70	72±2	240n6	210	240	245	240
17	110n6	205	165						80m6	170	130								1740	535	570	690	395	80	81±2	250n6	230	250	260	250
18							110n6	205	165						80m6	170	130		1860	535	570	690	395	80	81±2	270n6	230	275	285	280
19	130n6	245	200						100n6	210	165								2010	610	630	790	448	90	91±2	290n6	245	-	295	285
20				130n6	245	200									100n6	210	165		2130	610	630	790	448	90	91±2	330n6	245	-	315	310
21	130n6	245	200												100n6	210	165		2140	690	690	830	473	100	100±2	320n6	280	-	335	330
22				130n6	245	200									100n6	210	165		2250	690	690	830	473	100	100±2	340n6	280	-	345	340
23	150n6	245	200												110n6	210	165		2380	770	770	930	528	115	120±2	360n6	350	-	365	360
24				150n6	245	200									110n6	210	165		2510	770	770	930	528	115	120±2	380n6	350	-	385	380
25	150n6	245	200												110n6	210	165		2580	845	865	1045	585	130	120±2	400n6	380	-	405	400
26				150n6	245	200									110n6	210	165		2760	845	865	1045	585	130	120±2	420n6	380	-	435	430

规格 Size	D ₅	e ₂	e ₃	E	g	G ₁	G ₂	G ₃	G ₄	G ₅	G ₇	h ⁻¹	h ₁	h ₂	H	l ₂	m ₁	m ₂	m ₃	n ₁	n ₂	n ₃	n ₄	s	润滑油 oil(l)	重量 weight (kg)		
13	48	405	265	635	211.5	1125	335	1160	335	480	1180	440	450	460	900	350	545	545	475	100	305	835	340	35	130	110	2380	2260
14	48	475	265	705	211.5	1195	335	1230	335	480	1250	440	450	460	900	350	545	685	475	100	375	905	340	35	140	115	2750	2615
15	55	485	320	762	238	1367	380	1402	380	550	1420	500	490	500	1000	410	655	655	535	120	365	1005	375	42	210	160	3730	3540
16	55	530	320	808	238	1413	380	1448	380	550	1470	500	490	500	1000	410	655	745	535	120	410	1050	375	42	220	165	3955	3765
17	55	525	370	860	259	1560	415	1600	415	600	1620	550	555	560	1100	410	735	735	600	135	390	1145	425	42	290	230	4990	4760
18	55	585	370	920	259	1620	415	1660	415	600	1680	550	555	560	1100	470	735	855	600	135	450	1205	425	42	300	235	5495	5240
19	65	590	420	997	299	1832	465	1877	465	670	1900	620	615	620	1240	470	850	850	690	155	435	1345	475	48	380	360	7000	6500
20	65	650	420	1057	299	1892	465	1937	465	670	1960	620	615	620	1240	500	850	970	690	155	495	1405	475	48	440	420	8100	7600
21	75	655	450	1067	310	1902	490	1947	490	715	1970	700	685	690	1390	500	900	900	720	170	485	1400	520	56	370	420	9200	8600
22	75	710	450	1122	310	1957	490	2002	490	725	2025	700	685	690	1390	550	900	1010	720	170	540	1455	520	56	430	490	9900	9400
23	80	730	490	1185	342	2130	540	2175	540	785	2200	780	770	790	1570	590	1010	1010	810	180	550	1560	580	56	520	560	11500	10600
24	80	795	490	1250	342	2195	540	2240	540	805	2265	780	770	790	1570	590	1010	1140	810	180	615	1625	580	56	600	650	13400	12500
25	90	790	490	1325	400	2270	605	2315	605	875	2315	860	860	860	1720	650	1090	1090	910	200	590	1685	660	66	720	790	16000	15100
26	90	880	490	1415	400	2360	605	2405	605	900	2430	860	860	860	1720	650	1090	1270	910	200</								



四级传动
卧式安装
类型 WV4.H
规格 5-12

Four stage
Horizontal
Type WV4.H
Sizes 5-12

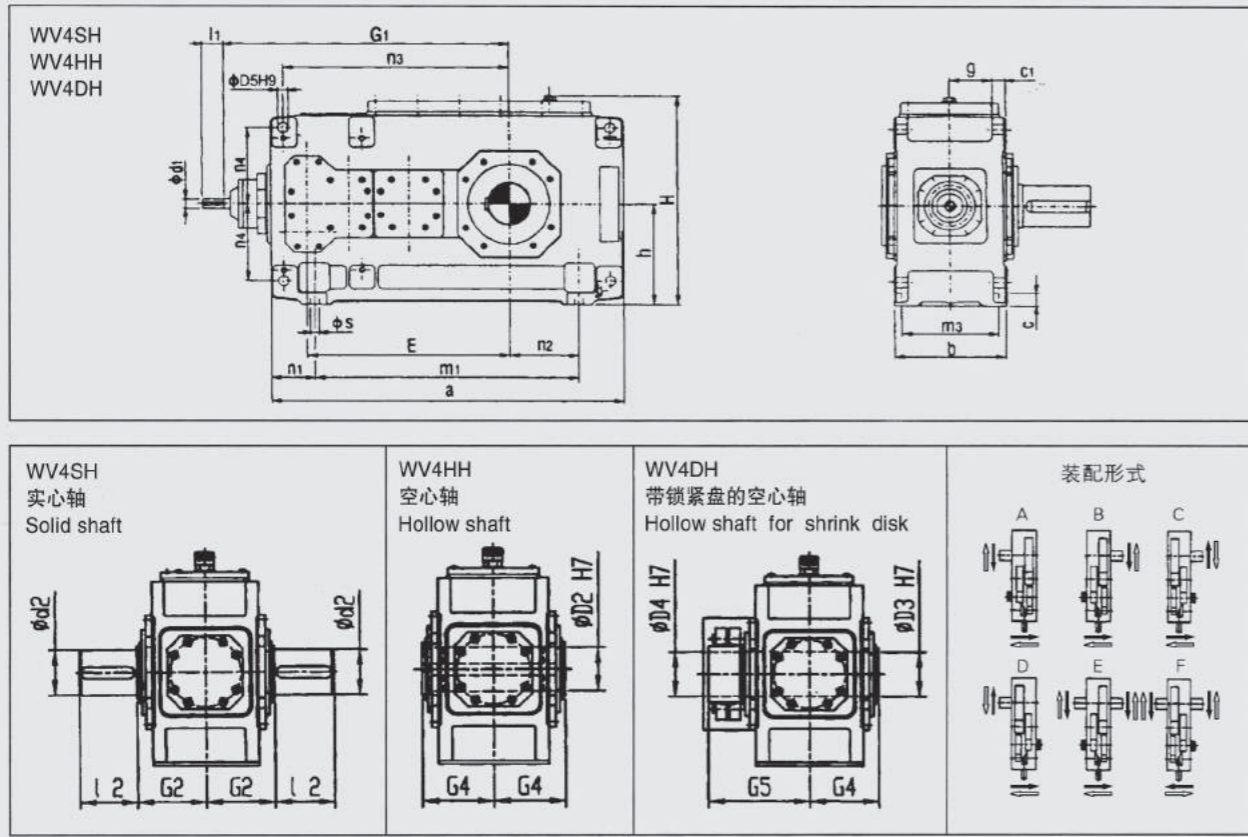

规格 Size	in=80-180		in=100-224		in=200-315		in=250-40		a	b	c	c ₁	d ₂	D ₂	D ₃	D ₄	D ₅	E	g
	d ₁	l ₁	d ₁	l ₁	d ₁	l ₁	d ₁	l ₁											
5	28m6	55			28k6	50			690	255	28	30±1	100m6	95	100	100	24	405	97.5
6			28m6	50			20k6	50	770	255	28	30±1	110n6	105	110	110	24	440	97.5
7	30m6	70			25m6	60			845	300	35	36±1	120n6	115	120	120	28	495	114
8			30m6	70			25m6	60	950	300	35	36±1	130n6	125	130	130	28	540	114
9	35m6	80			28m6	60			1000	370	40	45±1.5	140n6	135	145	140	36	580	140
10			35m6	80			28m6	60	1100	370	40	45±1.5	160n6	150	155	150	36	630	140
11	45m6	100			35m6	80			1200	430	50	54±1.5	170n6	165	170	165	40	705	161
12			45m6	100			35m6	80	1355	430	50	54±1.5	180n6	180	185	180	40	775	161

规格 Size	G ₁	G ₂	G ₄	G ₅	h ⁻¹	h _s	H	l ₂	m ₁	m ₃	n ₁	n ₂	n ₃	n ₄	s	润滑油 oil(l)	重量 weight (kg)
6	650	165	165	240	230	100	482	210	560	220	105	145	490	180	19	18	385
7	725	195	195	280	280	140	572	210	605	260	120	130	560	215	24	30	555
8	770	195	195	285	280	130	585	250	710	260	120	190	605	215	24	33	655
9	840	235	235	330	320	135	662	250	710	320	145	155	660	245	28	48	890
10	890	235	235	350	320	135	662	300	810	320	145	205	710	245	28	50	1025
11	1010	270	270	400	380	170	782	300	870	370	165	180	805	300	35	80	1485
12	1080	270	270	405	380	160	790	300	1025	370	165	265	875	300	35	90	1750



四级传动
卧式安装
类型 WV4.H, WV4.M
规格 13-26

Four stage
Horizontal
Type WV4.H, WV4.M
Sizes 13-26

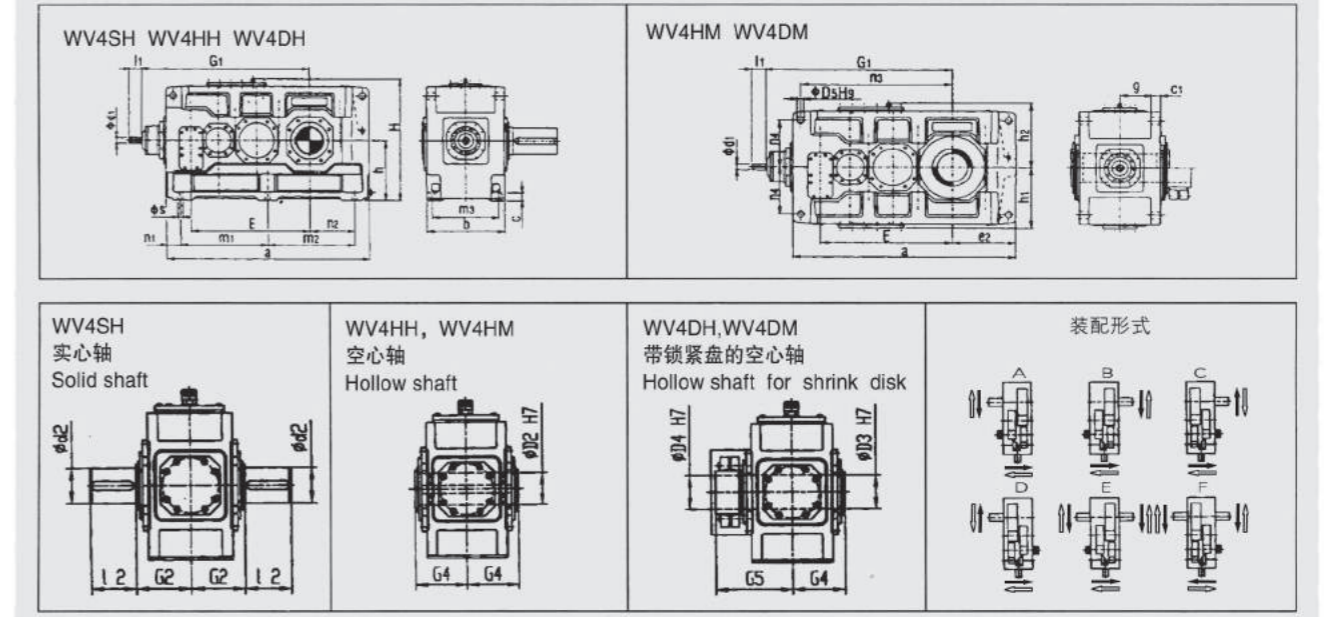

规格 Size	in=100-180		in=90-200		in=100-224		in=200-315		in=224-355		in=250-450		a	b	c	c ₁	d ₂	D ₂	D ₃	D ₄	D ₅
	d ₁	l ₁	d ₁	l ₁	d ₁	l ₁	d ₁	l ₁	d ₁	l ₁	d ₁	l ₁									
13	55m6	110					40m6	100					1395	550	60	61±2	200n6	190	195	190	48
14					55m6	110					40m6	100	1535	550	60	61±2	210n6	210	215	210	48
15	70m6	135					50m6	110					1680	625	70	72±2	230n6	230	235	230	55
16			70m6	135					50m6	110			1770	625	70	72±2	240n6	240	245	240	55
17	70m6	135					50m6	110					1770	690	80	81±2	250n6	250	260	250	55
18			70m6	135					50m6	110			1890	690	80	81±2	270n6	275	285	280	55
19	80m6	165					60m6	140					2030	790	90	91±2	290n6	-	295	285	65
20			80m6	165					60m6	140			2150	790	90	91±2	330n6	-	315	310	65
21	90m6	165					70m6	140					2340	830	100	100±2	320n6	-	335	330	75
22			90m6	165					70m6	140			2450	830	100	100±2	340n6	-	345	340	75
23	90m6	165					70m6	140					2530	930	115	120±2	360n6	-	365	360	80
24			90m6	165					70m6	140			2660	930	115	120±2	380n6	-	385	380	80
25	110m6	205					80m6	170					2830	1045	130	120±2	400n6	-	405	400	90
26			110m6	205					80m6	170			3010	1045	130	120±2	420n6	-	435	430	90

规格 Size	G ₁	e ₂	E	g	G ₂	G ₄	G ₅	h ⁻¹	h ₁	h ₂	H	l ₂	m ₁	m ₂	m ₃	n ₁	n ₂	n ₃	n ₄	s	润滑油(l)				重量 weight (kg)
																					B3.H B3.M B2.H B2.M				
																					B3.H	B3.M	B2.H	B2.M	
13	1170	405	820	211.5	335	335	480	440	450	460	900	350	597.5	597.5	475	100	305	940	340	35	145	120	2395	2280	
14	1240	475	890	211.5	335	335	480	440	450	460	900	350	597.5	737.5	475	100	375	1010	340	35	150	125	2735	2650	
15	1402	485	987	238	380	380	550	500	490	500	1000	410	720	720	535	120	365	1135	375	42	230	170	3630	3435	
16	1448	530	1033	238	380	380	550	500	490	500	1000	410	720	810	535	120	410	1180	375	42	235	175	3985	3765	
17	1450	525	1035	259	415	415	600	550	555	560	1100	410	750	750	600	135	390	1175	425	42	295	230	4695	4460	
18	1510	585	1095	259	415	415	600	550	555	560	1100	470	750	870	600	135	450	1235	425	42	305	235	5200	4930	
19	1680	590	1190	299	465	465	670	620	615	620	1240	470	860	860	690	155	435	1365	475	48	480	440	6800	6300	
20	1740	650	1250	299	465	465	670	620	615	620	1240	500	860	980	690	155	495	1425	475	48	550	510	8200	7700	
21	1992	655	1387	310	490	490	715	700	685	690	1390	500	1000	1000	720	170	485	1600	520	56	540	590	9200	8600	
22	2047	710	1442	310	490	490	725	700	685	690	1390	550	1000	1110	720	170	540	1655	520	56	620	680	9900	9400	
23	2110	730	1505	342	540	540	785	780	770	790	1570	590	1085	1085	810	180	550	1725	580	56	710	790	16100	10700	
24	2175	795	1570	342	540	540	805	780	770	790	1570	590	1085	1215	810	180	615	1790	580	56	810	910	13500	12600	
25	2395	790	1695	400	605	605	875	860	860	860	1720	650	1215	1215	910	200	590	1965	660	66	1000	1110	16100	15200	
26	2485	880	1785	400	605	605	900	860	860	860	1720	650	1215	1395	910	200	680	2055	660	66	1100	1200	17600	16500	



两级传动
立式安装
类型 WH2.H
规格 4-12

Two stage
Vertical
Type WH2.H
Sizes 4-12

WH2SV WH2HV WH2DV(浸油润滑 With dip lubrication)

WH2SV WH2HV WH2DV(强制润滑 With forced lubrication)

WH2SV
实心轴
Solid shaft

WH2HV
空心轴
Hollow shaft

WH2DV
带胀紧盘的空心轴
Hollow shaft for shrink disk

布置形式 Design:

A, D 布置形式按客户要求供货
Design A&D on request

规格 Size	in=6.3-11.2		in=8-14		in=12.5-22.4		in=16-28		a	b ₁	c	d ₂	D ₂	D ₃	D ₄	e ₄	e ₅	e ₆	E
	d ₁	l ₁	d ₁	l ₁	d ₁	l ₁	d ₁	l ₁											
4	45m6	100			32m6	80			565	150	30±1	80m6	80	85	85	200	215	320	270
5	50m6	100			38m6	80			640	240	30±1	100m6	95	100	100	230	252	385	315
6			50m6	100			38m6	80	720	240	30±1	110n6	105	110	110	230	252	425	350
7	60m6	135			50m6	110			785	240	36±1	120n6	115	120	120	280	292	425	385
8			60m6	135			50m6	110	890	240	36±1	130n6	125	130	130	280	302	485	430
9	75m6	140			60m6	140			925	330	45±1.5	140n6	135	145	140	320	342	560	450
10			75m6	140			60m6	140	1025	330	45±1.5	160n6	150	155	150	320	342	610	500
11	90m6	165			70m6	140			1105	330	54±1.5	170n6	165	170	165	380	402	595	545
12			90m6	165			70m6	140	1260	330	54±1.5	180n6	180	185	180	380	410	680	615

规格 Size	f ₁	f ₂	f ₃	G ₁	G ₂	G ₄	G ₅	G ₆	h	h ₁	l ₂	m ₁	m ₂	n ₁	n ₂	P ₁	P ₂	s	润滑油 oil(l)		重量 weight (kg)
																			(1)**	(2)**	
4	28	22	-	170	140	140	205	140	107.5	165	170	505	300	30	260	35	220	24	23	-	190
5	38	28	150	195	165	165	240	165	127.5	205	210	580	360	30	175	35	270	24	35	17.5	300
6	38	28	150	195	165	165	240	165	127.5	205	210	660	360	30	220	35	270	24	37	18.5	355
7	42	30	145	210	195	195	280	195	150	205	210	715	430	35	215	35	330	28	62	31	505
8	42	32	145	210	195	195	285	195	150	205	250	820	430	35	275	35	330	28	69	35	590
9	42	32	135	240	235	235	330	235	185	275	250	845	490	40	260	40	370	36	98	49	830
10	42	32	135	240	235	235	350	235	185	275	300	945	490	40	310	40	370	36	110	55	960
11	48	35	145	275	270	270	400	270	215	275	300	1005	600	50	295	50	440	40	160	80	1335
12	48	35	145	275	270	270	405	270	215	275	300	1160	600	50	380	50	440	40	180	90	1615

(1)** 浸油润滑, (2)** 强制润滑。

(1)** Dip lubrication, (2)** Forced lubrication.



两级传动
立式安装
类型 WH2.V
规格 13-22

Two stage
Vertical
Type WH2.V
Sizes 13-22

WH2SV WH2HV WH2DV(强制润滑 With forced lubrication)

WH2SH
实心轴
Solid shaft

WH2HH
空心轴
Hollow shaft

WH2DH
带胀紧盘的空心轴
Hollow shaft for shrink disk

布置形式 Design:

A, D 布置形式按客户要求供货
Design A&D on request

规格 Size	in=6.3-11.2		in=7.1-12.5		in=8-14		in=12.5-20		in=14-22.4		in=16-25		a	b	c	d ₂	D ₂	D ₃	D ₄	E	
	d ₁	l ₁	d ₁	l ₁	d ₁	l ₁	d ₁	l ₁	d ₁	l ₁	d ₁	l ₁									
13	100m6	205					85m6	170					1290	900	61±2	200n6	190	195	190	635	
14					100m6	205					85m6	170	1430	900	61±2	210n6	210	215	210	705	
15	120n6	210					100m6	210					1550	980	72±2	230n6	230	235	230	762	
16			120n6	210					100m6	210			1640	980	72±2	240n6	240	245	240	808	
17	125n6	245					110n6	210					1740	1110	81±2	250n6	250	260	250	860	
18			125n6	245					110n6	210			1860	1110	81±2	270n6	275	285	280	920	
19																					
20																					
21																					
22																					

按客户要求供货
On request

规格 Size	f ₁	f ₂	f ₃	G ₁	G ₂	G ₄	G ₅	G ₆	h	l ₂	m ₁	m ₂	n ₁	n ₂	P ₁	P ₂	s	润滑油 oil(l)		重量 weight (kg)	
																		(1)**	(2)**		
13	53	35	130	330	335	335	480	335	272.5	350	1195	680	50	360	50	500	48	80	1880		
14	53	35	130	330	335	335	480	335	272.5	350	1335	680	50	430	50	500	48	90	2430		
15	63	42	130	365	380	380	550	380	310	410	1435	750	60	430	50	570	55	140	3240		
16	63	42	130	365	380	380	550	380	310	410	1525	750	60	475	50	570	55	150	3465		
17	60	42	170	420	415	415	600	415	340	410	1610	850	70	465	70	630	55	175	4420		
18	60	42	170	420	415	415	600	415	340	470	1730	850	70	525	70	630	55	185	4870		
19																					
20																					
21																					
22																					

按客户要求供货
On request



三级传动
立式安装
类型 WH3.V
规格 5-12

Three stage
Vertical
Type WH3.V
Sizes 5-12

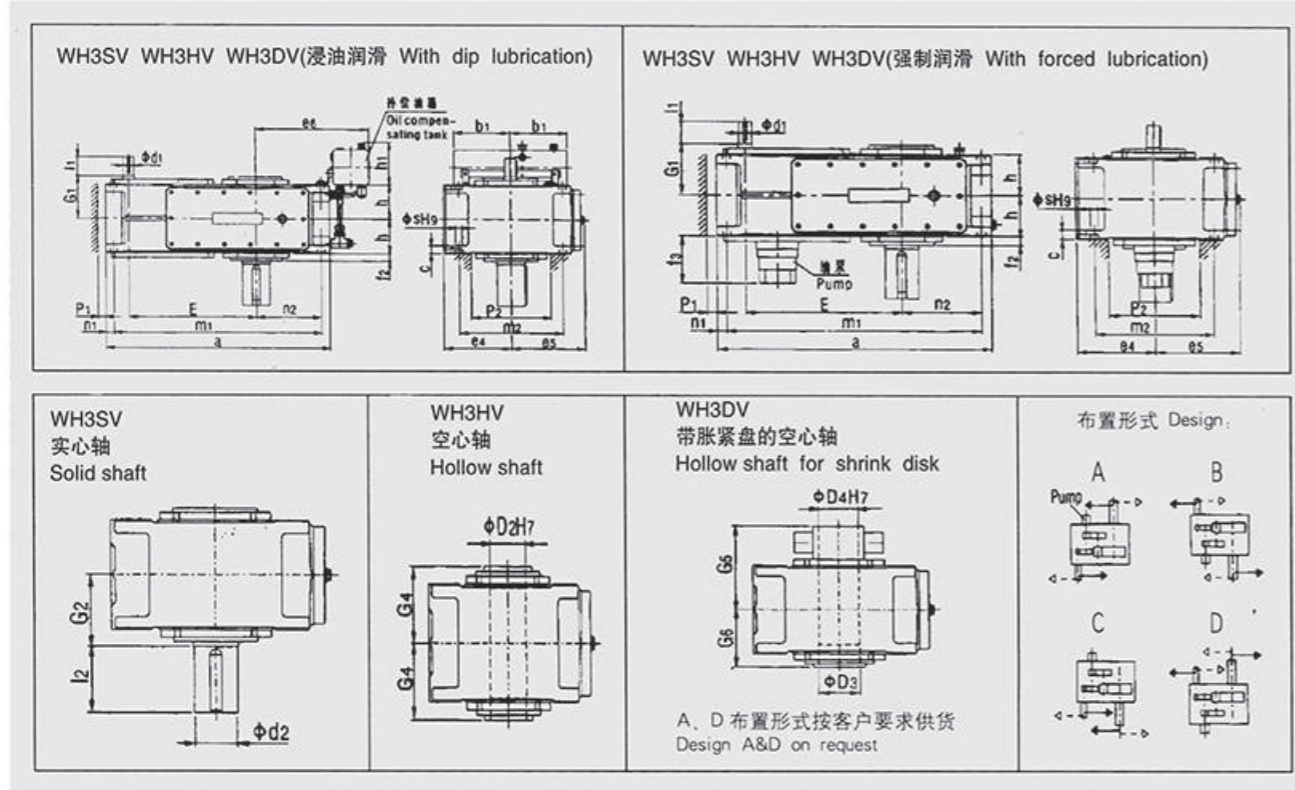

规格 Size	in=25-45		in=31.5-56		in=50-63		in=63-80		in=71-90		in=90-112		a	b ₁	c	d ₂	D ₂	D ₃	D ₄	e _s	e _s
	d ₁	l ₁	d ₁	l ₁	d ₁	l ₁	d ₁	l ₁	d ₁	l ₁	d ₁	l ₁									
5	40m6	70			30m6	50			24k6	40			690	240	30±1	100m6	95	100	100	230	252
6			40m6	70			30m6	50			24k6	40	770	240	30±1	110n6	105	110	110	230	252
7	45m6	80			35m6	60			28m6	50			845	240	36±1	120n6	115	120	120	280	292
8			45m6	80			35m6	60			28m6	50	950	240	36±1	130n6	125	130	130	280	302
9	60m6	125			45m6	100			32m6	80			1000	330	45±1.5	140n6	135	145	140	320	342
10			60m6	125			45m6	100			32m6	80	1100	330	45±1.5	160n6	150	155	150	320	342
11	70m6	120			50m6	80			42m6	70			1200	330	54±1.5	170n6	165	170	165	380	402
12			70m6	120			50m6	80			42m6	70	1355	330	54±1.5	180n6	180	185	180	380	410

规格 Size	e ₆	E	f ₂	f ₃	G ₁	G ₂	G ₄	G ₅	G ₆	h	h ₁	l ₂	m ₁	m ₂	n ₁	n ₂	P ₁	P ₂	s	润滑油 oil(l)		重量 weight (kg)
																				(1)**	(2)**	
5	385	405	28	190	160	165	165	240	165	127.5	205	210	630	360	30	175	35	270	24	36	14	320
6	425	440	28	190	160	165	165	240	165	127.5	205	210	710	360	30	220	35	270	24	40	17	365
7	425	495	30	185	185	195	195	280	195	150	205	210	775	430	35	215	35	330	28	64	35	540
8	485	540	32	185	185	195	195	285	195	150	205	250	880	430	35	275	35	330	28	75	47	625
9	560	580	32	170	230	235	235	330	235	185	275	250	920	490	40	260	40	370	36	110	55	875
10	610	630	32	170	230	235	235	350	235	185	275	300	1020	490	40	310	40	370	36	120	60	1020
11	595	705	35	170	255	270	270	400	270	215	275	300	1100	600	50	295	50	440	40	190	70	1400
12	680	775	35	170	255	270	270	405	270	215	275	300	1255	600	50	380	50	440	40	205	80	1675

(1)** 浸油润滑. (2)** 强制润滑.

(1)** Dip lubrication. (2)** Forced lubrication.



三级传动
立式安装
类型 WH3.V
规格 13-22

Three stage
Vertical
Type WH3.V
Sizes 13-22

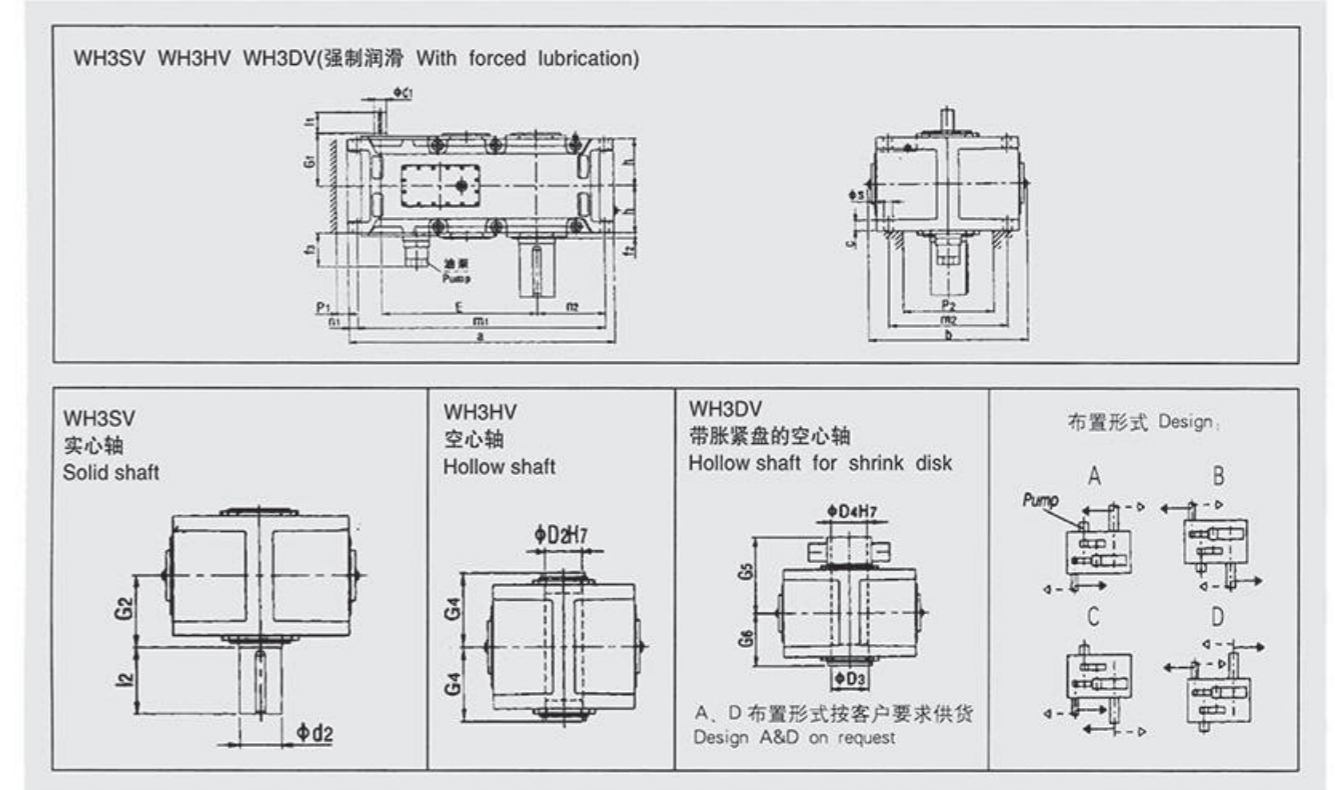

规格 Size	in=22.4-45		in=25-50		in=28-56		in=50-63		in=56-71		in=63-80		in=71-90		in=80-100		in=90-112		a	b	c	d ₂	D ₂
	d ₁	l ₁	d ₁	l ₁	d ₁	l ₁	d ₁	l ₁	d ₁	l ₁	d ₁	l ₁	d ₁	l ₁	d ₁	l ₁	d ₁	l ₁					
13	85m6	160					60m6	135					50m6	110					1395	900	61±2	200n6	190
14					85m6	160						60m6	135				50m6	110	1535	900	61±2	210n6	210
15	100m6	200					75m6	140					60m6	140					1680	980	72±2	230n6	230
16			100m6	200					75m6	140						60m6	140		1770	980	72±2	240n6	240
17	100m6	200					75m6	140					60m6	140					1770	1110	81±2	250n6	250
18			100m6	200					75m6	140						60m6	140		1890	1110	81±2	270n6	275
19	按客户要求供货																						
20	On request																						
21	On request																						
22	On request																						

规格 Size	D ₃	D ₄	E	f ₂	f ₃	G ₁	G ₂	G ₄	G ₅	G ₆	h	l ₂	m ₁	m ₂	n ₁	n ₂	P ₁	P ₂	s	润滑油 oil(l)	重量 weight (kg)	
																						13
14	215	210	890	35	170	310	335	335	480	335	272.5	350	1440	680	50	430	50	500	48	140	2490	
15	235	230	987	42	170	350	380	380	550	380	310	410	1565	750	60	430	50	570	55	200	3260	
16	245	240	1033	42	170	350	380	380	550	380	310	410	1655	750	60	475	50	570	55	220	3625	
17	260	250	1035	42	210	380	415	415	600	415	340	410	1640	850	70	465	70	630	55	240	4250	
18	285	280	1095	42	210	380	415	415	600	415	340	470	1760	850	70	525	70	630	55	250	4740	
19	按客户要求供货																					
20	On request																					
21	On request																					
22	On request																					



四级传动
立式安装
类型 WH4.V
规格 7-12

Four stage
Vertical
Type WH4.V
Sizes 7-12

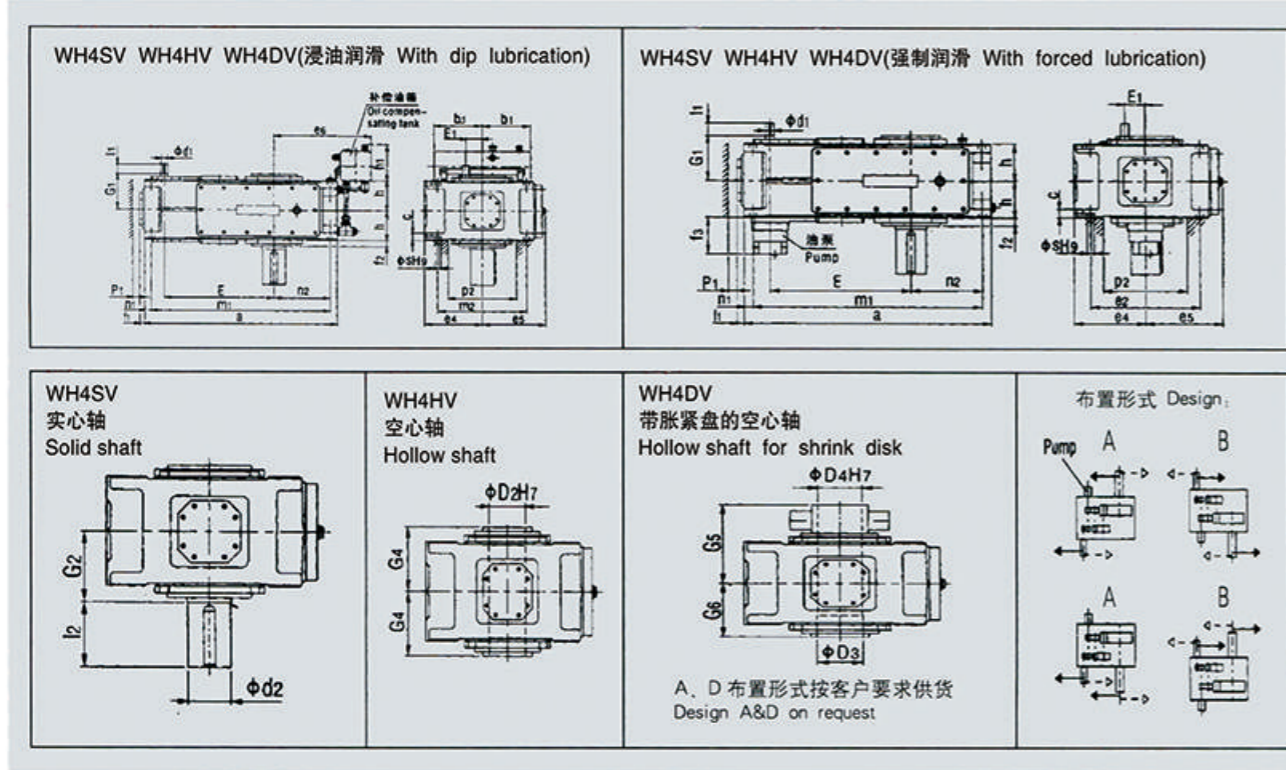

规格 Size	in=100-180		in=125-224		in=200-355		in=250-450		a	b ₁	c	d ₂	D ₂	D ₃	D ₄	e ₄	e ₅	E	
	d ₁	l ₁	d ₁	l ₁	d ₁	l ₁	d ₁	l ₁											
7	30m6	50			24k6	40			845	240	36±1	120n6	115	120	120	280	292	425	495
8			30m6	50			24k6	40	950	240	36±1	130n6	125	130	130	280	302	485	540
9	35m6	60			28m6	50			1000	330	45±1.5	140n6	135	145	140	320	342	560	580
10			35m6	60			28m6	50	1100	330	45±1.5	160n6	150	155	150	320	342	610	630
11	45m6	100			32m6	80			1200	330	54±1.5	170n6	165	170	165	380	402	595	705
12			45m6	100			32m6	80	1355	330	54±1.5	180n6	180	185	180	380	410	680	775

规格 Size	E ₁	f ₁	f ₂	f ₃	G ₁	G ₂	G ₄	G ₅	G ₆	h	h ₁	l ₂	m ₁	m ₂	n ₁	n ₂	P ₁	P ₂	s	润滑油 oil(l)		重量 weight (kg)
																				(1)**	(2)**	
7	80	37	30	160	180	195	195	280	195	150	205	210	775	430	35	215	35	330	28	60	30	550
8	80	37	32	160	180	195	195	285	195	150	205	250	880	430	35	275	35	330	28	65	35	645
9	90	43	32	170	215	235	235	330	235	185	275	250	920	490	40	260	40	370	36	105	45	875
10	90	43	32	170	215	235	235	350	235	185	275	300	1020	490	40	310	40	370	36	120	60	1010
11	110	47	35	170	250	270	270	400	270	215	275	300	1100	600	50	295	50	440	40	175	80	1450
12	110	47	35	170	250	270	270	405	270	215	275	300	1255	600	50	380	50	440	40	200	95	1725

(1)** 浸油润滑, (2)** 强制润滑。

(1)** Dip lubrication, (2)** Forced lubrication.



四级传动
立式安装
类型 WH4.V
规格 13-22

Four stage
Vertical
Type WH4.V
Sizes 13-22

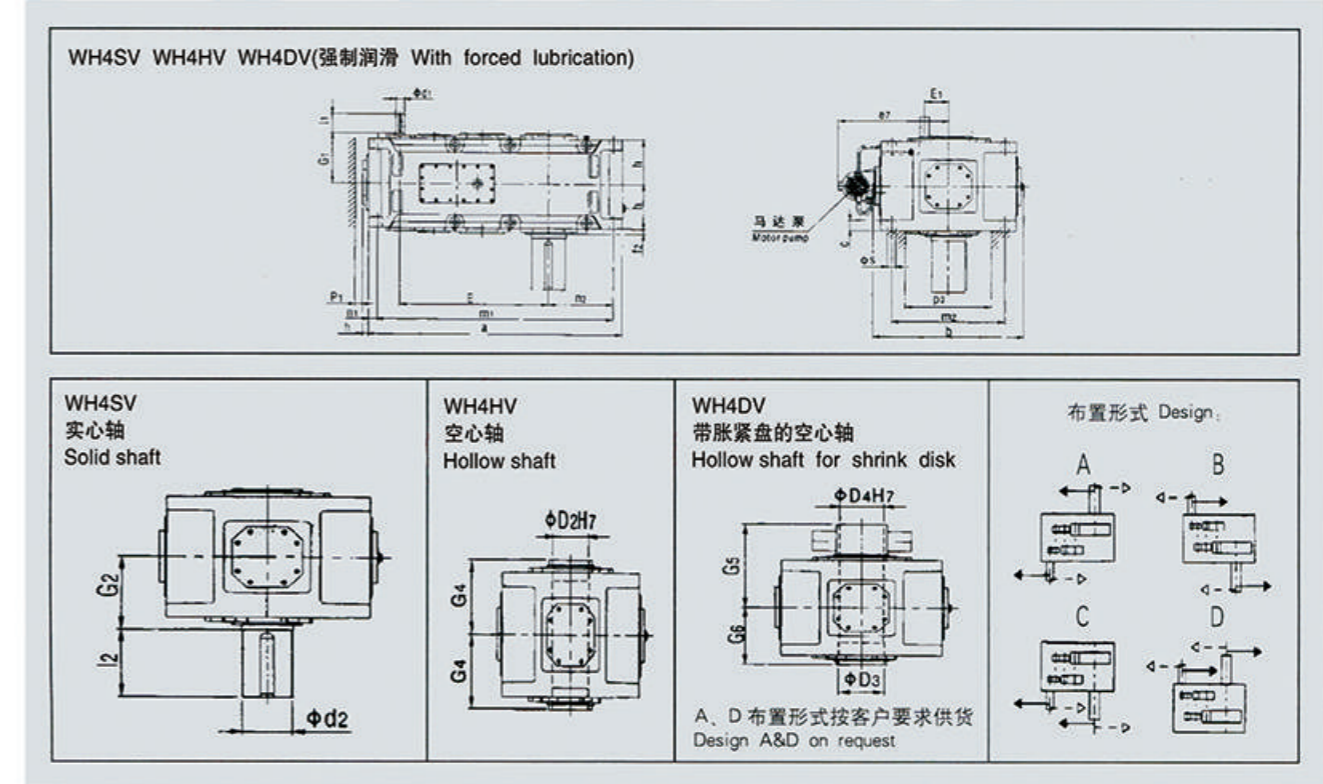

规格 Size	in=100-180		in=112-200		in=125-224		in=200-355		in=224-400		in=250-450		a	b	c	d ₂	D ₂	D ₃	D ₄	e ₂
	d ₁	l ₁	d ₁	l ₁	d ₁	l ₁	d ₁	l ₁	d ₁	l ₁	d ₁	l ₁								
13	50m6	100					38m6	80					1395	900	61±2	200n6	190	195	190	690
14					50m6	100					38m6	80	1535	900	61±2	210n6	210	215	210	690
15	60m6	135					50m6	110					1680	980	72±2	230n6	230	235	230	730
16			60m6	135						50m6	110		1770	980	72±2	240n6	240	245	240	730
17	60m6	105					50m6	80					1770	1110	81±2	250n6	250	260	250	790
18			60m6	105					50m6	80			1890	1110	81±2	270n6	275	285	280	790
19	按客户要求供货 On request																			
20	按客户要求供货 On request																			
21	按客户要求供货 On request																			
22	按客户要求供货 On request																			

规格 Size	E	E ₁	f ₁	f ₂	G ₁	G ₂	G ₄	G ₅	G ₆	h	l ₂	m ₁	m ₂	n ₁	n ₂	P ₁	P ₂	s	润滑油 oil(l)		重量 weight (kg)
																			(1)**	(2)**	
13	820	130	47	35	305	335	335	480	335	272.5	350	1300	680	50	360	50	500	48	110	2270	
14	890	130	47	35	305	335	335	480	335	272.5	350	1440	680	50	430	50	500	48	120	2600	
15	987	160	56	42	345	380	380	550	380	310	410	1565	750	60	430	60	570	55	170	3440	
16	1033	160	56	42	345	380	380	550	380	310	410	1655	750	60	475	60	570	55	180	3740	
17	1035	160	53	42	380	415	415	600	415	340	410	1640	850	70	465	70	630	55	220	4450	
18	1095	160	53	42	380	415	415	600	415	340	470	1760	850	70	525	70	630	55	230	4915	
19	按客户要求供货 On request																				
20	按客户要求供货 On request																				
21	按客户要求供货 On request																				
22	按客户要求供货 On request																				



两级传动
立式安装
类型 WV2.V
规格 4-12

Two stage
Vertical
Type WV2.V
Sizes 4-12

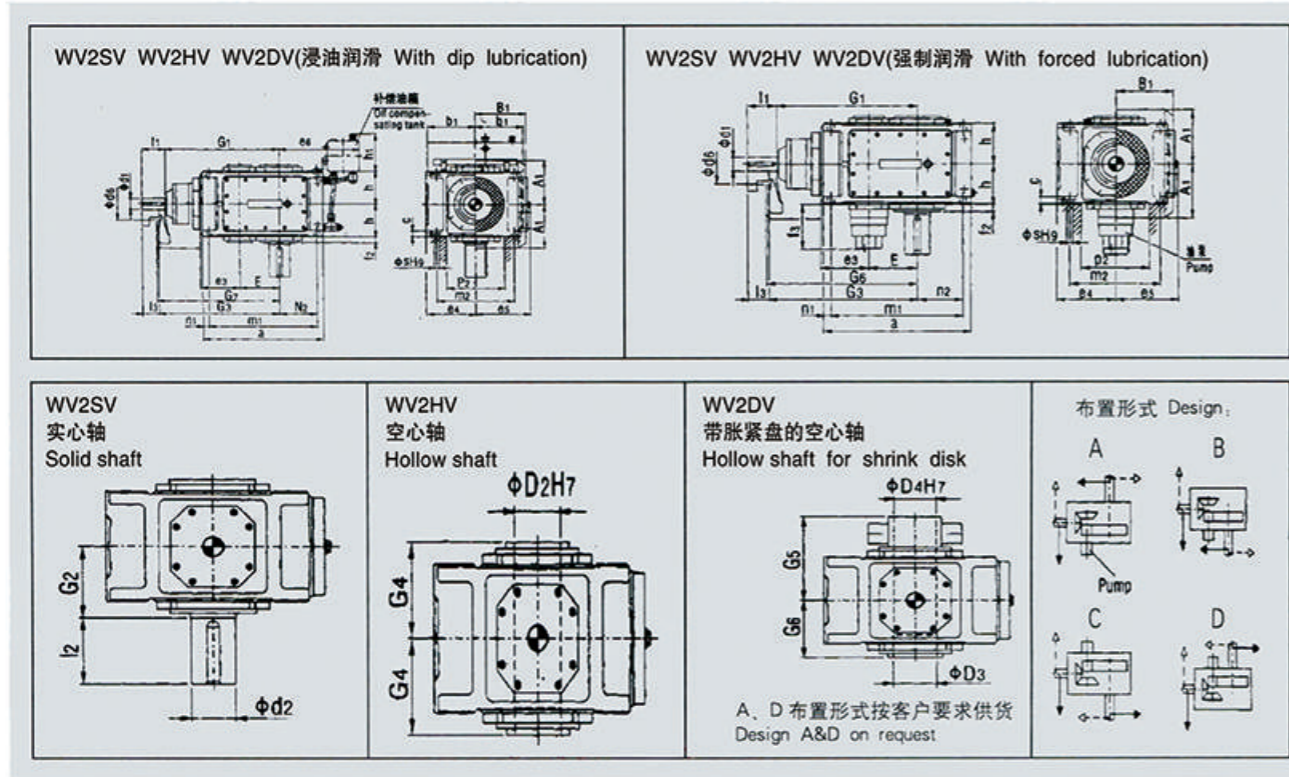

规格 Size	iN=5-11.2			iN=6.3-14			a	A ₁	b ₁	B ₁	c	d ₂	d ₆	D ₂	D ₃	D ₄	e ₃	e ₄	e ₅
	d ₁	l ₁	l ₃	d ₁	l ₁	l ₃													
4	45m6	100	80				505	188	150	200	30±1	80m6	150	80	85	85	100	200	215
5	55m6	110	80				565	215	240	235	30±1	100m6	160	95	100	100	185	230	252
6				55m6	110	80	645	215	240	235	30±1	110n6	160	105	110	110	185	230	252
7	70m6	135	105				690	250	240	285	36±1	120n6	210	115	120	120	225	280	302
8				70m6	135	105	795	250	240	285	36±1	130n6	210	125	130	130	225	280	302
9	80m6	165	130				820	270	330	325	45±1.5	140n6	195	135	145	140	265	320	342
10				80m6	165	130	920	270	330	325	45±1.5	160n6	195	150	155	150	265	320	342
11	90m6	165	130				975	328	330	385	54±1.5	170n6	210	165	170	165	320	380	410
12				90m6	165	130	1130	328	330	385	54±1.5	180n6	210	180	185	180	320	380	410

规格 Size	e ₆	E	f ₂	f ₃	G ₁	G ₂	G ₃	G ₄	G ₅	G ₆	G ₇	h	h ₁	l ₂	m ₁	m ₂	n ₁	n ₂	P ₂	s	润滑油 oil(l)		重量 weight (kg)
																					(1)**	(2)**	
4	320	160	26	-	465	170	485	170	235	170	495	135	165	170	445	300	30	160	220	24	30	-	235
5	385	185	30	190	535	200	565	200	275	200	575	160	205	210	505	360	30	175	270	24	45	25	360
6	425	220	30	190	570	200	600	200	275	200	610	160	205	210	585	360	30	220	270	24	55	28	410
7	425	225	32	200	640	235	670	235	320	235	685	190	205	210	620	430	35	215	330	28	80	40	615
8	485	270	32	200	685	235	715	235	325	235	730	190	205	250	725	430	35	275	330	28	100	45	700
9	560	265	45	200	755	270	790	270	365	270	805	220	275	250	740	490	40	260	370	36	125	60	1000
10	610	315	45	200	805	270	840	270	385	270	855	220	275	300	840	490	40	310	370	36	150	70	1155
11	595	320	47	200	925	320	960	320	450	320	980	265	275	300	875	600	50	295	440	40	220	100	1640
12	680	390	47	200	995	320	1030	320	455	320	1050	265	275	300	1030	600	50	380	440	40	240	110	1910

(1)** 浸油润滑, (2)** 强制润滑。

(1)** Dip lubrication, (2)** Forced lubrication.



两级传动
立式安装
类型 WV2.V
规格 13-18

Two stage
Vertical
Type WV2.V
Sizes 13-18

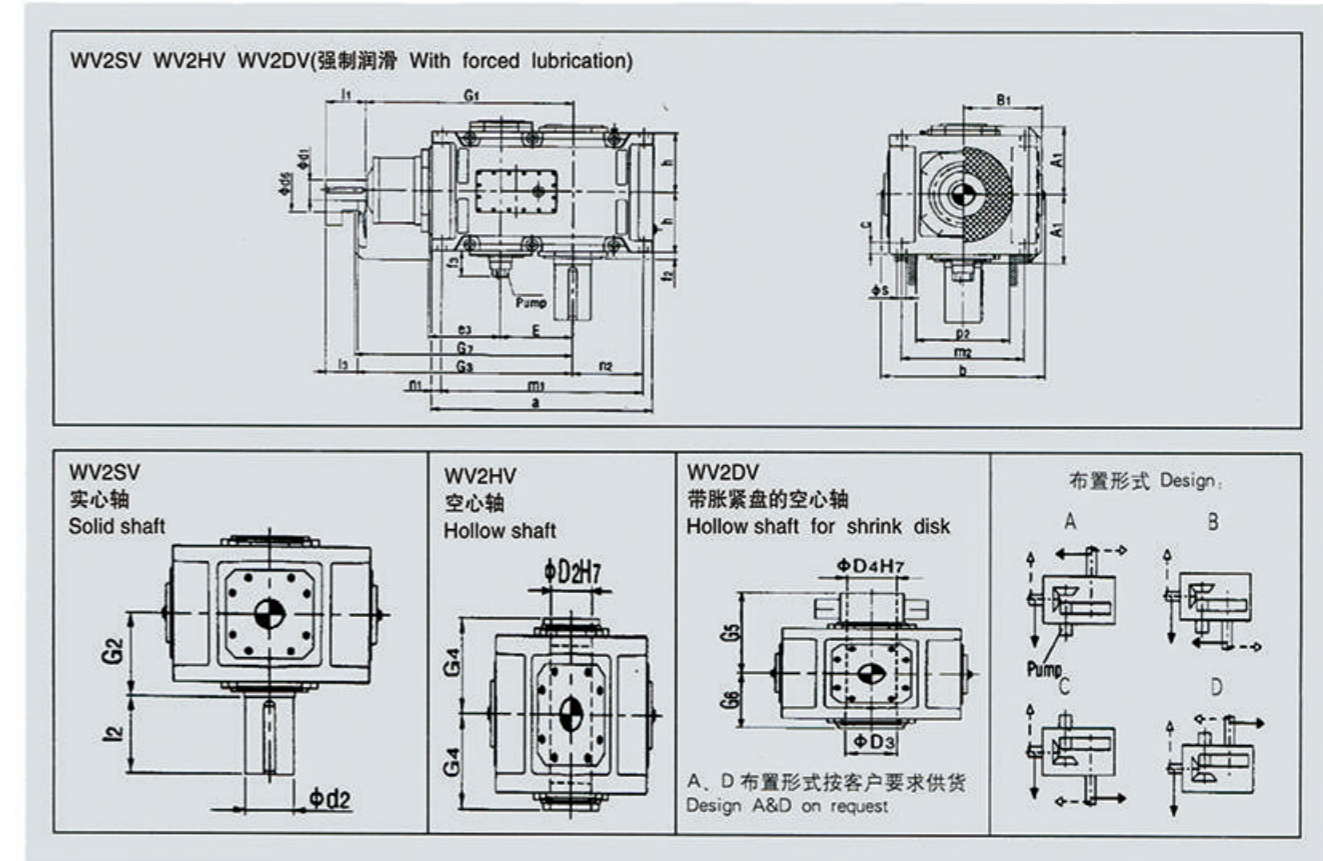

规格 Size	iN=5-11.2			iN=5.6-11.2			iN=5.6-12.5			iN=6.3-14			iN=7.1-12.5			a	A ₁	b	B ₁	c	d ₂	d ₆	D ₂	D ₃			
	d ₁	l ₁	l ₃	d ₁	l ₁	l ₃	d ₁	l ₁	l ₃	d ₁	l ₁	l ₃	d ₁	l ₁	l ₃												
13	110n6	205	165													1130	375	900	450	61±2	200n6	245	190	195			
14												110n6	205	165		1270	375	900	450	61±2	210n6	245	210	215			
15	130n6	245	200													1350	435	980	495	72±2	230n6	280	230	235			
16												130n6	245	200		1440	435	980	495	72±2	240n6	280	240	245			
17																1490	505	1110	555	81±2	250n6	380	250	260			
18																150n6	245	200									
																150n6	245	200	1610	505	1110	555	81±2	270n6	380	275	285

规格 Size	D ₄	e ₃	E	f ₂	f ₃	G ₁	G ₂	G ₃	G ₄	G ₅	G ₆	G ₇	h	l ₂	m ₁	m ₂	n ₁	n ₂	P ₂	s	润滑油 oil(l)	重量 weight (kg)
14	210	380	440	45	200	1140	390	1180	335	480	335	1200	325	350	1175	680	50	430	500	48	140	2725
15	230	450	442	75	200	1277	460	1322	380	550	380	1340	380	410	1235	750	60	430	570	55	190	3795
16	240	450	488	75	200	1323	460	1368	380	550	380	1385	380	410	1325	750	60	475	570	55	200	4160
17	250	510	490	98	200	1435	540	1480	415	600	415	1500	437.5	410	1360	840	70	465	630	65	270	5320
18	280	510	550	98	200	1495	540	1540	415	600	415	1560	437.5	470	1480	840	70	525	630	65	295	5860



三级传动
立式安装
类型 WV3.V
规格 4-12

Three stage
Vertical
Type WV3.V
Sizes 4-12

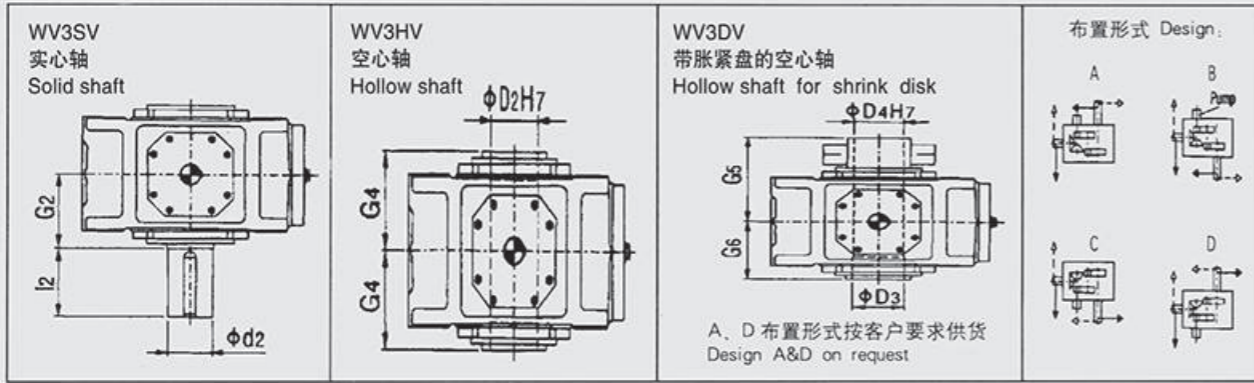
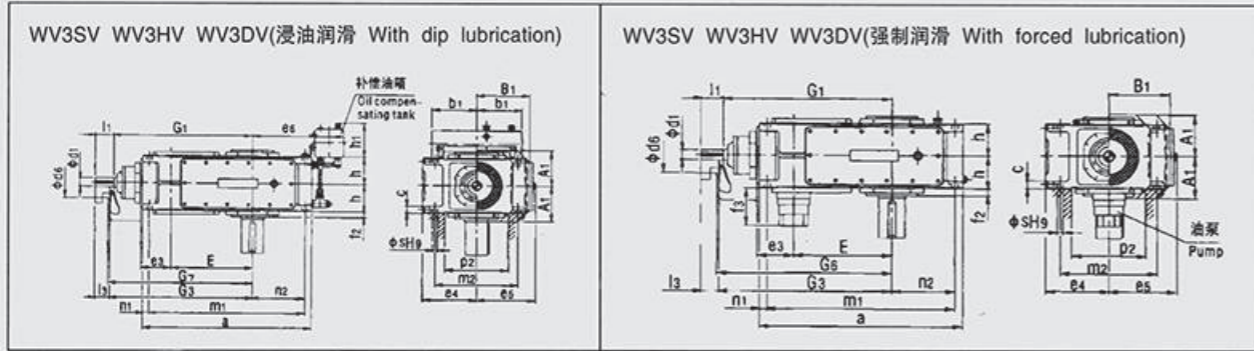

规格 Size	in=12.5-45			in=16-56			in=50-71			in=63-90			a	A ₁	b ₁	B ₁	c	d ₂	d ₆	D ₂	D ₃	D ₄	e ₃	e ₄
	d ₁	l ₁	l ₃	d ₁	l ₁	l ₃	d ₁	l ₁	l ₃	d ₁	l ₁	l ₃												
4	30m6	70	50				25m6	60	40				565	143	150	200	30±1	80m6	110	80	85	85	110	200
5	35m6	80	60				28m6	60	40				640	168	240	235	30±1	100m6	130	95	100	100	130	230
6				35m6	80	60				28m6	60	40	720	168	240	235	30±1	110n6	130	105	110	110	130	230
7	45m6	100	80				35m6	80	60				785	193	240	275	36±1	120n6	165	115	120	120	160	280
8				45m6	100	80				35m6	80	60	890	193	240	275	36±1	130n6	165	125	130	130	160	280
9	55m6	110	80				40m6	100	70				925	231	330	325	45±1.5	140n6	175	135	145	140	185	320
10				55m6	110	80				40m6	100	70	1025	231	330	325	45±1.5	160n6	175	150	155	150	185	320
11	70m6	135	105				50m6	110	80				1105	263	330	385	54±1.5	170n6	190	165	170	165	225	380
12				70m6	135	105				50m6	110	80	1260	263	330	385	54±1.5	180n6	190	180	185	180	225	380

规格 Size	e ₅	e ₆	E	f ₂	f ₃	G ₁	G ₂	G ₃	G ₄	G ₅	G ₆	G ₇	h	h ₁	l ₂	m ₁	m ₂	n ₁	n ₂	P ₂	s	润滑油 oil(l)		重量 weight (kg)
																						(1)**	(2)**	
4	215	320	270	22	-	500	140	520	140	205	140	530	107.5	165	170	505	300	30	160	220	24	28	-	210
5	252	385	315	28	190	575	165	595	165	240	165	605	127.5	205	210	580	360	30	175	270	24	34	17	325
6	252	425	350	28	190	610	165	630	165	240	165	640	127.5	205	210	660	360	30	220	270	24	36	18	380
7	292	425	385	30	190	690	195	710	195	280	195	720	150	205	210	715	430	35	215	330	28	60	25	550
8	302	485	430	32	190	735	195	755	195	285	195	765	150	205	250	820	430	35	275	330	28	68	30	635
9	342	560	450	32	180	800	235	830	235	330	235	845	185	275	250	845	490	40	260	370	36	120	55	890
10	342	610	500	32	180	850	235	880	235	350	235	895	180	275	300	945	490	40	310	370	36	130	60	1020
11	402	595	545	35	180	960	270	990	270	400	270	1010	215	275	300	1005	600	50	295	440	40	200	90	1455
12	410	680	615	35	180	1030	270	1060	270	405	270	1080	215	275	300	1160	600	50	380	440	40	220	100	1730

(1)** 浸油润滑, (2)** 强制润滑。

(1)** Dip lubrication, (2)** Forced lubrication.



三级传动
立式安装
类型 WV3.V
规格 13-22

Three stage
Vertical
Type WV3.V
Sizes 13-22

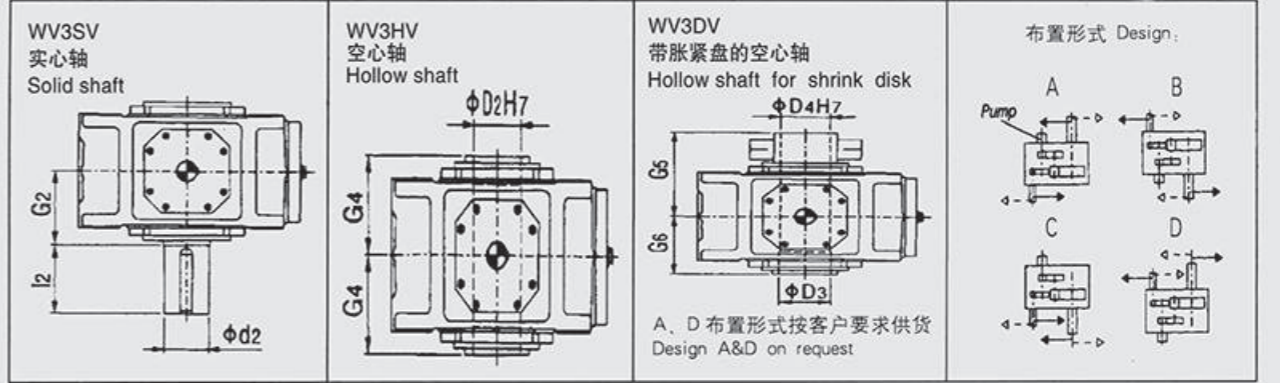
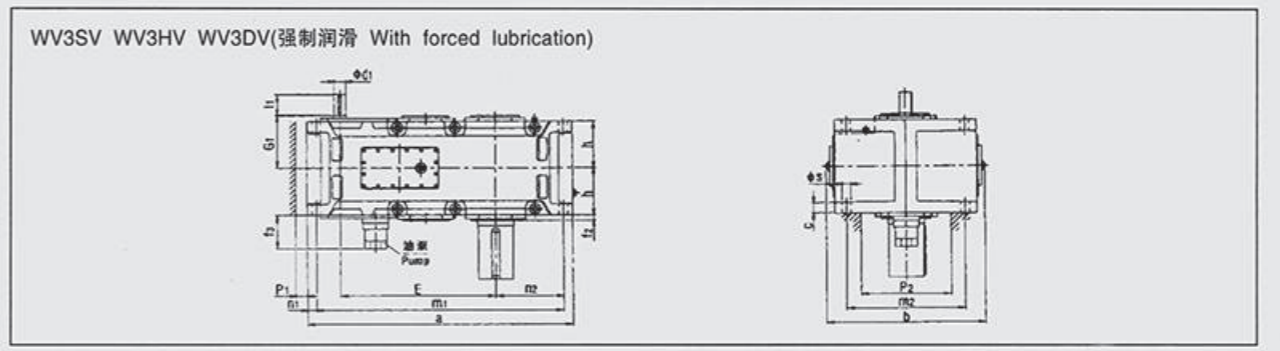

规格 Size	in=12.5-45			in=14-50			in=16-56			in=50-71			in=56-80			in=63-90			a	A ₁	b	B ₁	c	d ₂	d ₆	D ₂
	d ₁	l ₁	l ₃	d ₁	l ₁	l ₃	d ₁	l ₁	l ₃	d ₁	l ₁	l ₃	d ₁	l ₁	l ₃	d ₁	l ₁	l ₃								
13	80m6	165	130							60m6	140	105				1290	325	900	475	61±2	200n6	210	190			
14							80m6	165	130						60m6	140	105	1430	325	900	475	61±2	210n6	210	210	
15	90m6	165	130							70m6	140	105				1550	365	980	520	72±2	230n6	210	230			
16				90m6	165	130							70m6	140	105	1640	365	980	520	72±2	240n6	210	240			
17	110m6	205	165							80m6	170	130				1740	395	1110	570	81±2	250n6	230	250			
18				110m6	205	165							80m6	170	130	1860	395	1110	570	81±2	270n6	230	275			
19																										
20																										
21																										
22																										

按客户要求供货
On request

规格 Size	D ₃	D ₄	e ₃	E	f ₂	f ₃	G ₁	G ₂	G ₃	G ₄	G ₅	G ₆	G ₇	h	l ₂	m ₁	m ₂	n ₁	n ₂	P ₂	s	润滑油 oil(l)		重量 weight (kg)	
																						(1)**	(2)**		
13	195	190	265	635	35	170	1125	335	1160	335	480	335	1180	272.5	350	1195	680	50	360	500	48	115	2260		
14	215	210	265	705	35	170	1195	335	1230	335	480	335	1250	272.5	350	1335	680	50	430	500	48	130	2615		
15	235	230	320	762	42	170	1367	380	1402	380	550	380	1420	310	410	1435	750	60	430	570	55	180	3540		
16	245	240	320	808	42	170	1413	380	1448	380	550	380	1470	310	410	1525	750	60	475	570	55	190	3765		
17	260	250	370	860	42	170	1560	415	1600	415	600	415	1620	340	410	1610	850	70	465	630	65	260	4760		
18	285	280	370	920	42	170	1620	415	1660	415	600	415	1680	340	470	1730	850	70	525	630	65	275	5240		
19																									
20																									
21																									
22																									

按客户要求供货
On request



四级传动
立式安装
类型 WV4.V
规格 5-12

Four stage
Vertical
Type WV4.V
Sizes 5-12

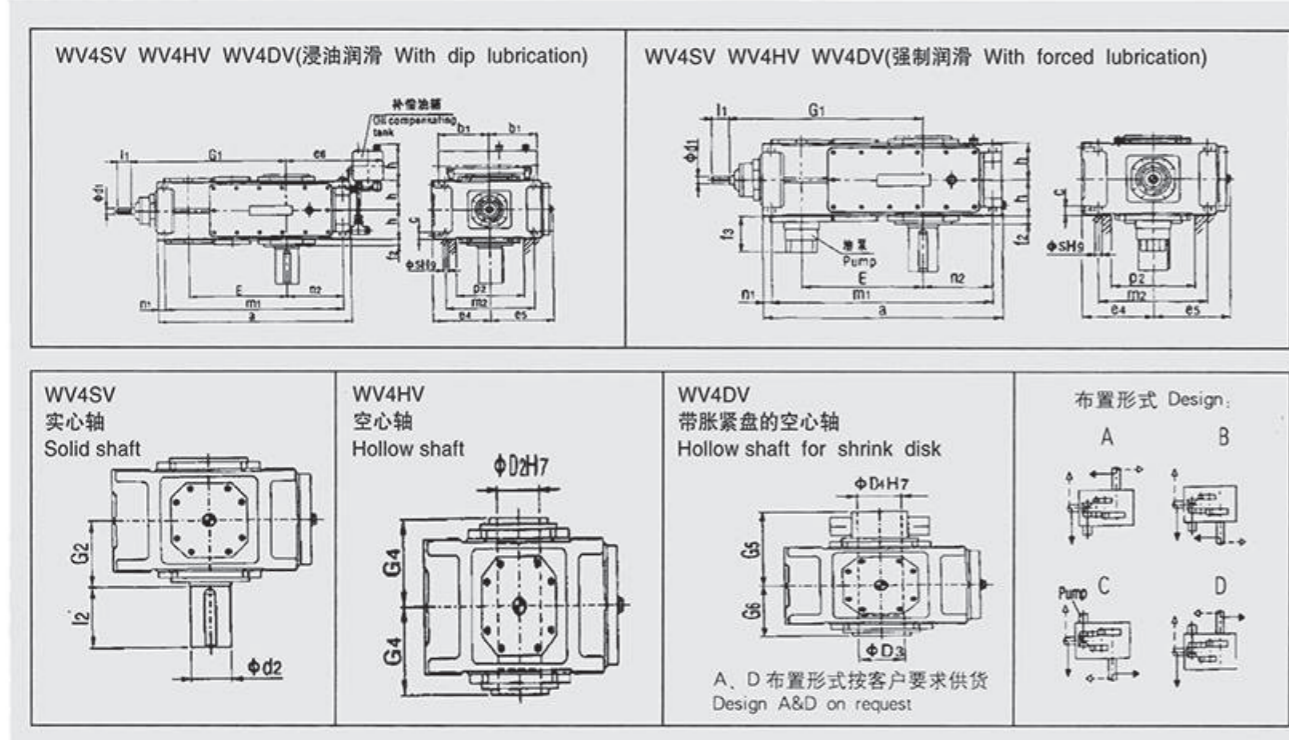

规格 Size	in=80-180		in=100-224		in=200-315		in=250-400		a	b ₁	c	d ₂	D ₂	D ₃	D ₄	e ₄	e ₅	e ₆
	d ₁	l ₁	d ₁	l ₁	d ₁	l ₁	d ₁	l ₁										
5	28m6	55			20k6	50			290	240	30±1	100m6	95	100	100	230	252	385
6			28m6	55			20k6	50	770	240	30±1	110n6	105	110	110	230	252	425
7	30m6	70			25m6	60			845	240	36±1	120n6	115	120	120	280	292	425
8			30m6	70			25m6	60	950	240	36±1	130n6	125	130	130	280	302	485
9	35m6	80			28m6	60			1000	330	45±1.5	140n6	135	145	140	320	342	560
10			35m6	80			28m6	60	1100	330	45±1.5	160n6	150	155	150	320	342	610
11	45m6	100			35m6	80			1200	330	54±1.5	170n6	165	170	165	380	402	595
12			45m6	100			35m6	80	1355	330	54±1.5	180n6	180	185	180	380	410	680

规格 Size	E	G ₁	f ₂	f ₃	G ₂	G ₄	G ₅	G ₆	h	h ₁	l ₂	m ₁	m ₂	n ₁	n ₂	P ₂	s	润滑油 oil(l)		重量 weight (kg)
																		(1)**	(2)**	
5	405	615	28	200	165	165	240	165	127.5	205	210	630	360	30	175	270	19	36	18	335
6	440	650	28	200	165	165	240	165	127.5	205	210	710	360	30	220	270	19	40	20	385
7	495	725	30	120	195	195	280	195	150	205	210	775	430	35	215	330	24	65	32	555
8	540	770	32	120	195	195	285	195	150	205	250	880	430	35	275	330	24	73	36	655
9	580	840	32	120	235	235	330	235	185	275	250	920	490	40	260	370	28	115	65	890
10	630	890	32	120	235	235	350	235	185	275	300	1020	490	40	310	370	28	140	75	1025
11	705	1010	35	130	270	270	400	270	215	275	300	1100	600	50	295	440	35	190	85	1485
12	775	1080	35	130	270	270	405	270	215	275	300	1255	600	50	380	440	35	200	100	1750

(1)** 浸油润滑, (2)** 强制润滑。

(1)** Dip lubrication, (2)** Forced lubrication.



四级传动
立式安装
类型 WV4.V
规格 13-22

Four stage
Vertical
Type WV4.V
Sizes 13-22

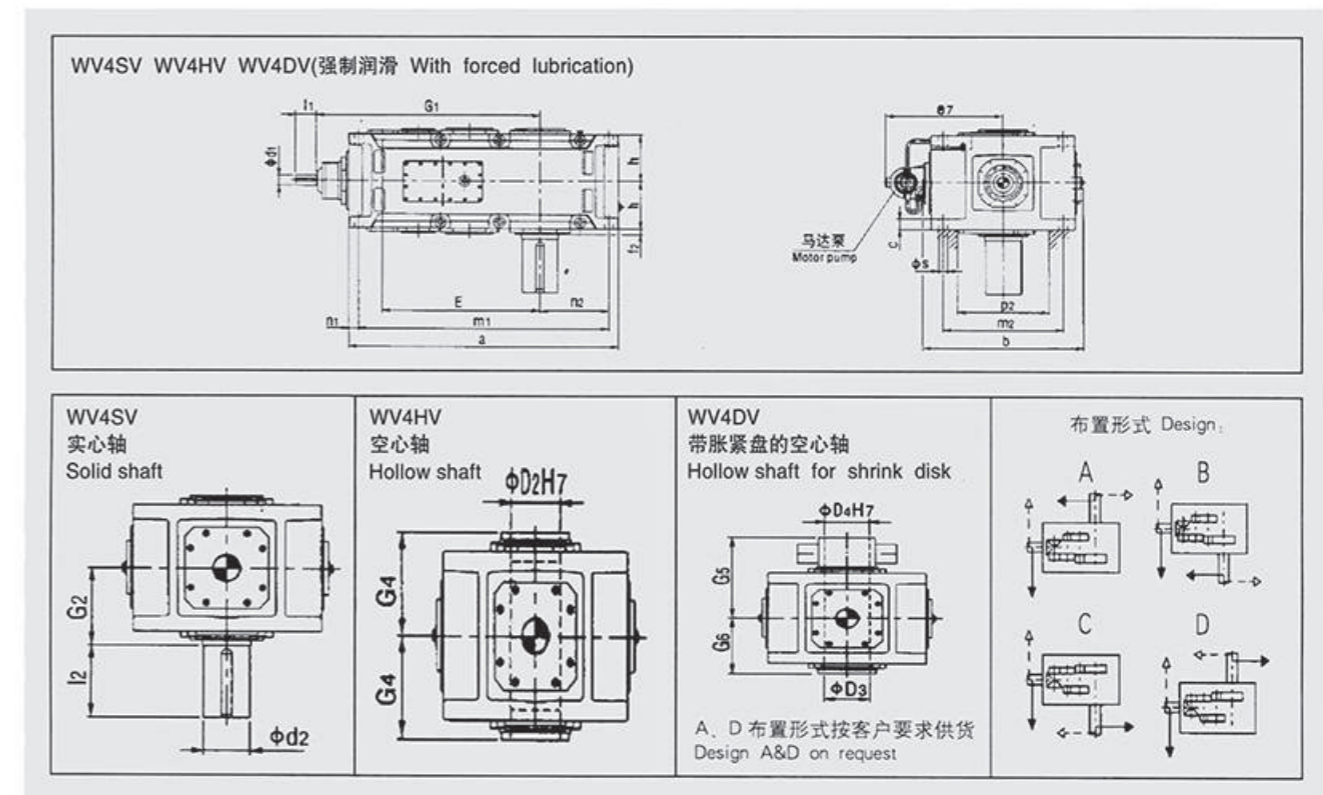

规格 Size	in=80-180		in=90-200		in=100-224		in=200-315		in=224-355		in=250-400		a	b	c	d ₂	D ₂	D ₃	
	d ₁	l ₁	d ₁	l ₁	d ₁	l ₁	d ₁	l ₁	d ₁	l ₁	d ₁	l ₁							
13	55m6	110					40m6	100					1395	900	61±2	200n6	190	195	
14					55m6	110					40m6	100	1535	900	61±2	210n6	210	215	
15	70m6	135					50m6	110					1680	980	72±2	230n6	230	235	
16			70m6	135					50m6	110			1770	980	72±2	240n6	240	245	
17	70m6	135					50m6	110					1770	1110	81±2	250n6	250	260	
18			70m6	135					50m6	110			1890	1110	81±2	270n6	275	285	
19																			
20																			
21																			
22																			

按客户要求供货
On request

规格 Size	D ₄	e ₇	E	f ₂	G ₁	G ₂	G ₄	G ₅	G ₆	h	l ₂	m ₁	m ₂	n ₁	n ₂	P ₂	s	润滑油 oil(l)		重量 weight (kg)
																		(1)**	(2)**	
13	190	690	820	35	1170	335	335	480	335	272.5	350	1300	680	50	360	500	48	135		2280
14	210	690	890	35	1240	335	335	480	335	272.5	350	1440	680	50	430	500	48	150		2605
15	230	730	987	42	1402	380	380	550	380	310	410	1565	750	60	430	570	55	210		3435
16	240	730	1033	42	1148	380	380	550	380	310	410	1655	750	60	475	570	55	240		3765
17	250	790	1035	42	1450	415	415	600	415	340	410	1640	850	70	465	630	65	270		4460
18	280	790	1095	42	1510	415	415	600	415	340	470	1760	850	70	525	630	65	285		4930
19																				
20																				
21																				
22																				

按客户要求供货
On request

齿轮箱冷却盘管尺寸图
卧式安装

Gear Units Cooling coils
Horizontal

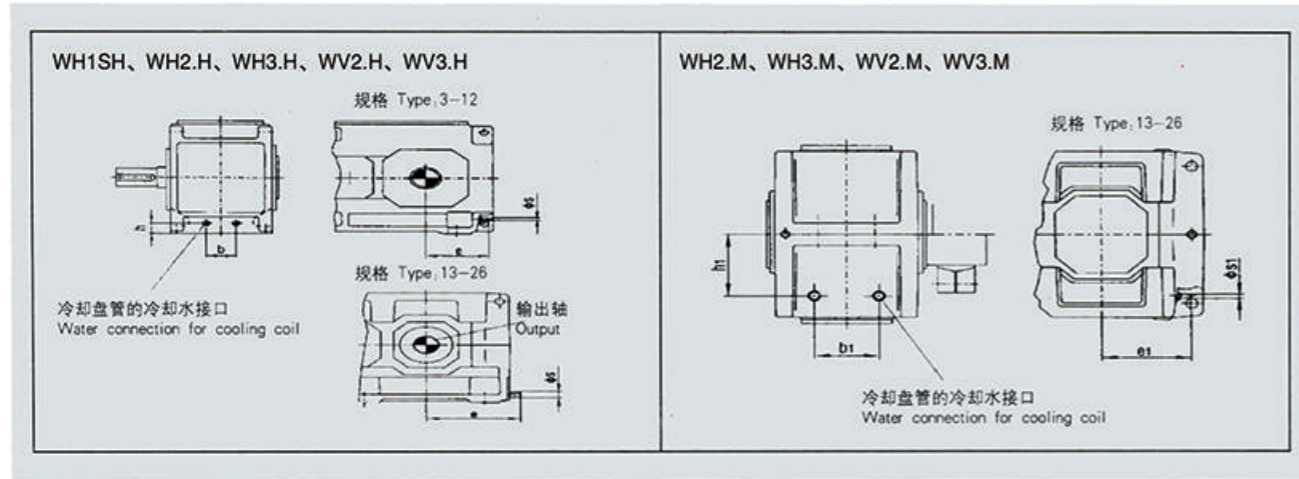

规格 Size	WH1SH					WH2H/WV3.H					WH3.H					WV2.H				
	b	e	h	s	水量 water quantity (l)	b	e	h	s	水量 water quantity (l)	b	e	h	s	水量 water quantity (l)	b	e	h	s	水量 water quantity (l)
3	48	205	74	G1/2	4	-	-	-	-	-	-	-	-	-	-	-	-	-	-	-
4	-	-	-	-	-	34	155	60	G1/2	4	-	-	-	-	-	74	160	54	G1/2	4
5	88	270	90	G1/2	4	68	170	64	G1/2	4	70	175	60	G1/2	4	130	175	62	G1/2	8
6	-	-	-	-	-	70	215	68	G1/2	4	70	220	69	G1/2	4	120	220	68	G1/2	4
7	124	310	135	G1/2	4	100	210	83	G1/2	4	80	210	83	G1/2	4	140	210	80	G1/2	8
8	-	-	-	-	-	100	270	83	G1/2	4	80	270	83	G1/2	4	140	270	80	G1/2	4
9	116	365	110	G1/2	8	140	245	110	G1/2	8	150	245	107	G1/2	4	232	245	110	G1/2	8
10	-	-	-	-	-	100	295	95	G1/2	8	90	295	95	G1/2	4	150	295	90	G1/2	8
11	146	425	130	G1/2	8	110	275	95	G1/2	8	200	275	115	G1/2	8	312	275	115	G1/2	8
12	-	-	-	-	-	200	360	109	G1/2	8	200	360	115	G1/2	8	300	360	115	G1/2	8
13	152	480	150	G1/2	8	252	455	116	G1/2	8	252	460	116	G1/2	8	324	460	116	G1/2	8
14	-	-	-	-	-	252	525	116	G1/2	8	252	530	116	G1/2	8	324	530	116	G1/2	8
15	172	560	130	G1/2	8	290	535	119	G1/2	8	290	540	119	G1/2	8	396	540	119	G1/2	8
16	-	-	-	-	-	290	580	119	G1/2	8	290	585	119	G1/2	8	396	585	119	G1/2	8
17	202	600	145	G1/2	8	340	575	134	G1/2	8	300	580	134	G1/2	8	468	580	134	G1/2	8
18	-	-	-	-	-	340	635	134	G1/2	8	300	640	134	G1/2	8	468	640	134	G1/2	8
19	按客户要求供货 on request					按客户要求供货 on request					按客户要求供货 on request									
20-26	-					按客户要求供货 on request					按客户要求供货 on request									

规格 Size	WH2M/WV3.M					WH3.M					WV2.M				
	b1	e1	h1	s1	水量 water quantity (l)	b1	e1	h1	s1	水量 water quantity (l)	b1	e1	h1	s1	水量 water quantity (l)
13	252	335	300	G1/2	8	252	335	300	G1/2	8	324	335	300	G1/2	8
14	252	405	300	G1/2	8	252	405	300	G1/2	8	324	405	300	G1/2	8
15	290	395	335	G1/2	8	290	395	340	G1/2	8	396	390	345	G1/2	8
16	290	440	335	G1/2	8	290	440	340	G1/2	8	396	435	345	G1/2	8
17	340	425	380	G1/2	8	300	425	380	G1/2	8	324	425	395	G1/2	8
18	340	485	380	G1/2	8	300	485	380	G1/2	8	324	485	395	G1/2	8
19-26	按客户要求供货 on request					按客户要求供货 on request					按客户要求供货 on request				

(1)** 浸油润滑, (2)** 强制润滑。

(1)** Dip lubrication, (2)** Forced lubrication.

齿轮箱冷却盘管尺寸图
立式安装

Gear Units Cooling coils
Vertical

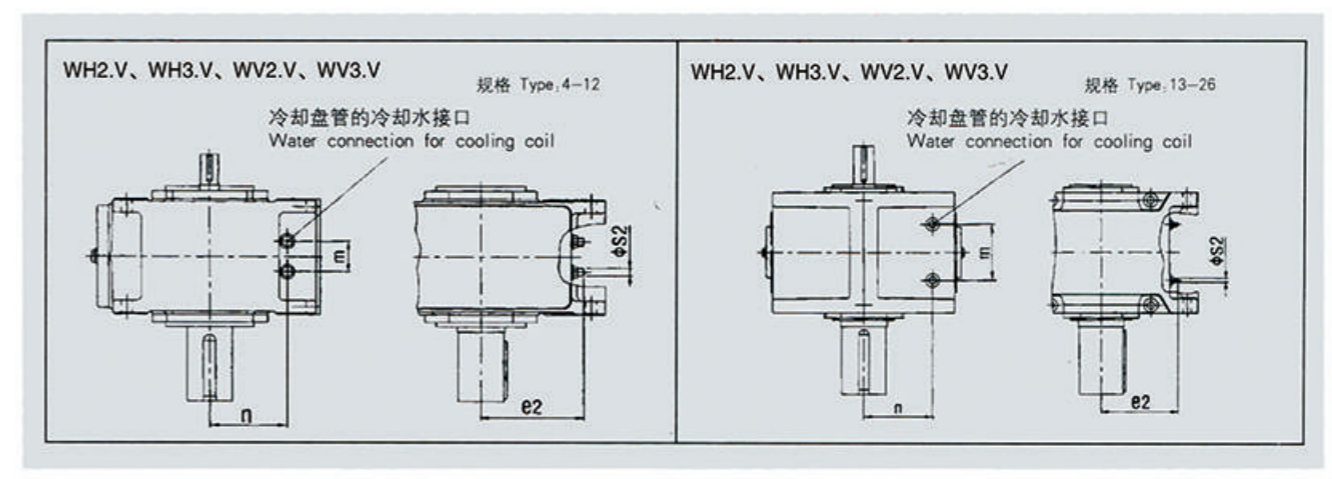

规格 Size	WH2.V/WV3.V					WH3.V					WV2.V				
	m	n	e2	s2	水量 water (l)	m	n	e2	s2	水量 water (l)	m	n	e2	s2	水量 water (l)
4	34	140	155	G1/2	4	-	-	-	-	-	74	146	160	G1/2	4
5	68	166	170	G1/2	4	70	170	175	G1/2	4	130	168	175	G1/2	8
6	70	162	215	G1/2	4	70	161	220	G1/2	4	120	162	220	G1/2	4
7	100	197	210	G1/2	4	80	197	210	G1/2	4	140	200	210	G1/2	8
8	100	197	270	G1/2	4	80	197	270	G1/2	4	140	200	270	G1/2	4
9	140	210	245	G1/2	8	150	213	245	G1/2	4	232	210	245	G1/2	8
10	100	225	295	G1/2	8	90	225	295	G1/2	4	150	230	295	G1/2	8
11	110	285	275	G1/2	8	200	265	275	G1/2	8	312	265	275	G1/2	8
12	200	271	360	G1/2	8	200	265	360	G1/2	8	300	265	360	G1/2	8
13	252	300	335	G1/2	8	252	300	335	G1/2	8	324	300	335	G1/2	8
14	252	300	405	G1/2	8	252	300	405	G1/2	8	324	300	405	G1/2	8
15	290	335	395	G1/2	8	290	340	395	G1/2	8	396	345	390	G1/2	8
16	290	335	440	G1/2	8	290	340	440	G1/2	8	396	345	435	G1/2	8
17	340	380	425	G1/2	8	300	380	425	G1/2	8	324	395	425	G1/2	8
18	340	380	485	G1/2	8	300	380	485	G1/2	8	324	395	485	G1/2	8
19-26	按客户要求供货 on request					按客户要求供货 on request					按客户要求供货 on request				

类型 Type	规格 Size	冷却盘管适用于 Cooling coil for												
		浸油润滑 Dip lubrication				法兰泵强制润滑 Forced lubrication with flanged-on pump				电动机强制润滑 Forced lubrication with motor pump				
		适用布置形式 For design				适用布置形式 For design				适用布置形式 For design				
		A	B	C	D	A	B	C	D	A	B	C	D	
WH2.V	4	√	√	√	√	-	-	-	-	-	-	-	-	-
	5-12	√	√	√	√	-	√	-	√	-	-	-	-	-
	13-18	-	-	-	-	-	√	-	√	-	-	-	-	-
WH3.V	5-12	√	√	√	√	-	√	-	√	-	-	-	-	-
	13-18	-	-	-	-	-	√	-	√	-	-	-	-	-
WV2.V	4	√	√	√	√	-	-	-	-	-	-	-	-	-
	5-12	√	√	√	√	-	√	-	√	-	-	-	-	-
	13-18	-	-	-	-	-	√	-	√	-	-	-	-	-
WV3.V	4	√	√	√	√	-	-	-	-	-	-	-	-	-
	5-12	√	√	√	√	-	-	-	-	-	-	-	-	-
	13-18	-	-	-	-	-	-	-	-	-	-	-	-	-

注: 冷却盘管适用于淡水、海水和半咸水。

Note: Cooling Coil suitable for fresh, sea and Brackish water.



带锁紧盘的空心轴
类型 WV2
规格 4-18

Hollow Shafts for Shrink Disks
Type WV2
Sizes 4-18

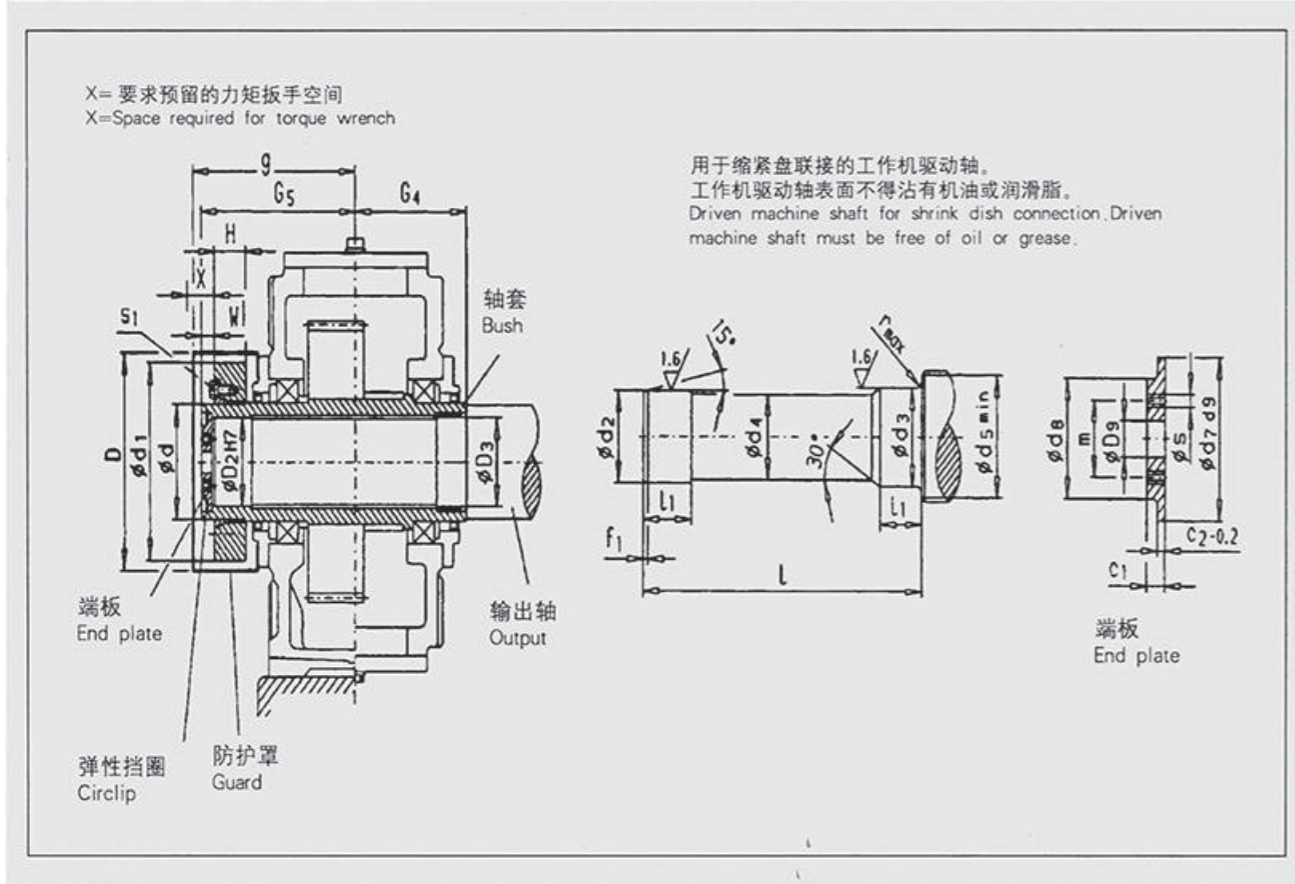

齿轮箱规格 Gear Units Sizes		类型type WV2D																											
		工作机驱动轴 ⁺ Driven machine shaft										端板 End plate				弹性挡圈 Ring Circlip		空心轴 Hollow shaft				缩紧盘 Shrink disk 1)				螺钉 Screw		防护罩 Guard	
		d ₂	d ₃	d ₄	d ₅	f ₁	l	l ₁	r	c ₁	c ₂	d ₆	D ₃	m	s	数量 Qty	DIN	D ₂	D ₃	G ₄	G ₅	类型/Type	d	d ₁	H	W	s ₁	D	g
4	85 g6	85 h6	84.5	95	4	386	48	2	17	7	90	70	22	50	M8	2	90x3	85	85	170	235	110-32	110	185	49	20	M12	235	250
5	100 g6	100 h6	99.5	114	5	453	53	3	20	8	105	80	26	55	M10	2	105x4	100	100	200	275	125-32	125	215	53	20	M12	275	285
6	110 g6	110 h6	109.5	124	5	453	58	3	20	8	115	85	26	60	M10	2	115x4	110	110	200	275	140-32	140	230	58	20	M14	285	285
7	120 g6	120 h6	119.5	134	5	533	68	3	20	8	125	90	26	65	M12	2	125x4	120	120	235	320	155-32	155	263	62	23	M14	330	335
8	130 g6	130 h6	129.5	145	6	538	73	3	20	8	135	100	26	70	M12	2	135x4	130	130	235	325	165-32	165	290	68	23	M16	340	340
9	140 g6	145 m6	139.5	160	6	609	82	4	23	10	150	110	33	80	M12	2	150x4	140	145	270	365	175-32	175	300	68	28	M16	360	380
10	150 g6	155 m6	149.5	170	6	629	92	4	23	10	160	120	33	90	M12	2	160x4	150	155	270	385	200-32	200	340	85	28	M16	395	400
11	165 f6	170 m6	164.5	185	7	744	112	4	23	10	175	130	33	90	M12	2	175x4	165	170	320	450	220-32	220	370	103	30	M20	435	470
12	180 f6	185 m6	179.5	200	7	749	122	4	23	10	190	140	33	100	M16	2	190x4	180	185	320	455	240-32	240	405	107	30	M20	450	470
14	210 f6	215 m6	209.5	233	8	894	147	5	28	14	220	170	33	130	M16	2	220x5	210	215	390	535	280-32	280	460	132	30	M20	525	555
16	240 f6	245 m6	239.5	263	8	1039	157	5	28	14	250	190	39	150	M20	2	250x5	240	245	450	620	320-32	320	520	140	35	M24	595	645
18	280 f6	285 m6	279.5	306	9	1177	177	5	30	14	290	210	39	160	M20	2	290x5	280	285	510	700	360-32	360	590	162	35	M24	635	725



带锁紧盘的空心轴
类型 WH2, WH3, WH4, WV3, WV4
规格 4-26

Hollow Shafts for Shrink Disks
Type WH2, WH3, WH4, WV3, WV4
Sizes 4-26

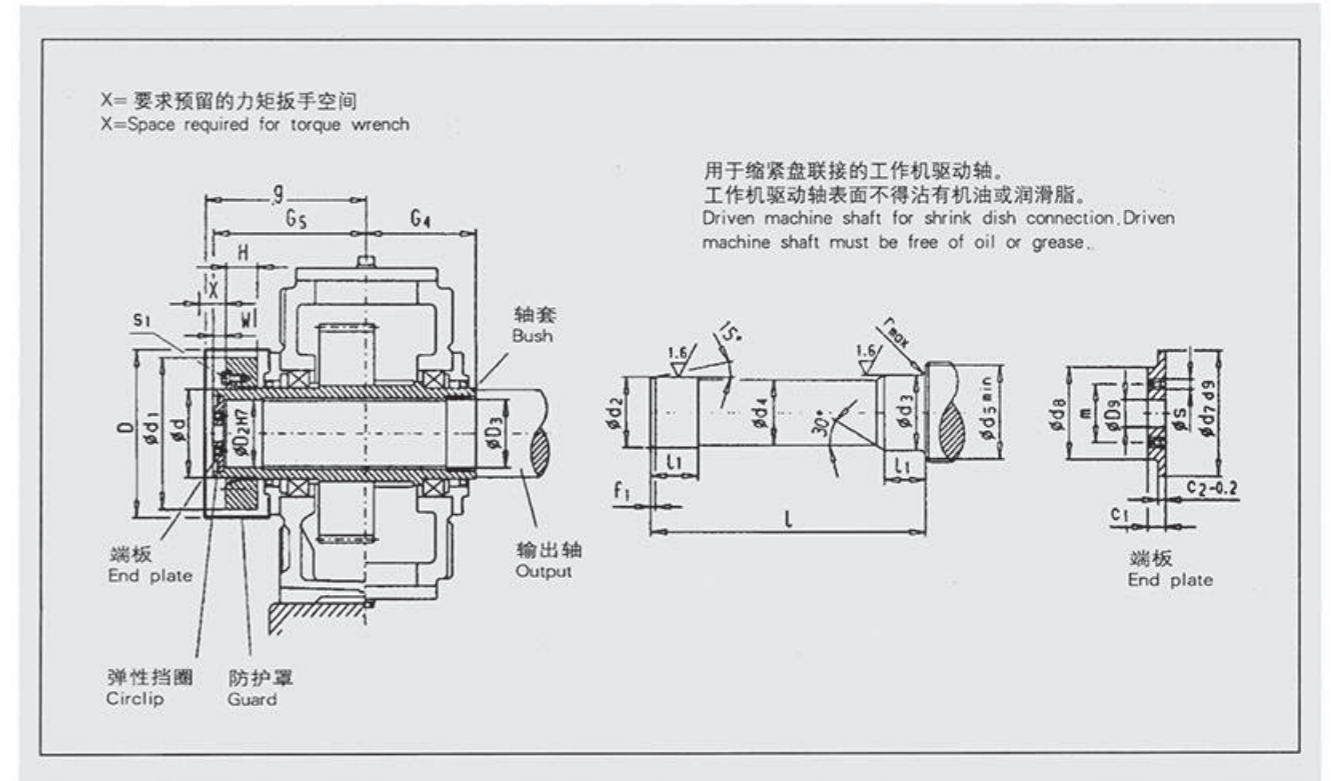

齿轮箱规格 Gear Units Sizes		类型type WH2D,WH3D, WH4D, WV3D, WV4D																											
		工作机驱动轴 ⁺ Driven machine shaft										端板 End plate				弹性挡圈 Ring Circlip		空心轴 Hollow shaft				缩紧盘 Shrink disk 1)				螺钉 Screw		防护罩 Guard	
		d ₂	d ₃	d ₄	d ₅	f ₁	l	l ₁	r	c ₁	c ₂	d ₇	d ₈	D ₃	m	s	数量 Qty	DIN	D ₂	D ₃	G ₄	G ₅	类型/Type	d	d ₁	H	W	s ₁	D
4	85 g6	85 h6	84.5	95	4	326	48	2	17	7	90	70	22	50	M8	2	90x3	85	85	140	205	110-32	110	185	49	20	M12	235	220
5	100 g6	100 h6	99.5	114	5	383	53	2	20	8	105	80	26	55	M10	2	105x4	100	100	165	240	125-32	125	215	53	20	M12	275	255
6	110 g6	110 h6	109.5	124	5	383	58	3	20	8	115	85	26	60	M10	2	115x4	110	110	165	240	140-32	140	230	58	20	M14	285	255
7	120 g6	120 h6	119.5	134	5	453	68	3	20	8	125	90	26	65	M12	2	125x4	120	120	195	280	155-32	155	263	62	23	M14	330	295
8	130 g6	130 h6	129.5	145	6	458	73	3	20	8	135	100	26	70	M12	2	135x4	130	130	195	285	165-32	165	290	68	23	M16	340	300
9	140 g6	145 m6	139.5	160	6	539	82	4	23	10	150	110	33	80	M12	2	150x4	140	145	235	330	175-32	175	300	68	28	M16	360	345
10	150 g6	155 m6	149.5	170	6	559	92	4	23	10	160	120	33	90	M12	2	160x4	150	155	235	350	200-32	200	340	85	28	M16	395	365
11	165 f6	170 m6	164.5	185	7	644	112	4	23	10	175	130	33	90	M12	2	175x4	165	170	270	400	220-32	220	370	103	30	M20	435	420
12	180 f6	185 m6	179.5	200	7	649	122	4	23	10	190	140	33	100	M16	2	190x4	180	185	270	405	240-32	240	405	107	30	M20	450	420
3	190 f6	195 m6	189.5	213	7	789	137	5	23	10	200	150	33	110	M16	2	200x4	190	195	335	480	260-32	260	430	119	30	M20	500	505
14	210 f6	215 m6	209.5	233	8	784	147	5	28	14	220	170	33	130	M16	2	220x5	210	215	335	480	280-32	280	460	132	30	M20	525	505
15	230 f6	235 m6	229.5	253	8	899	157	5	28	14	240	180	39	140	M16	2	240x5	230	235	380	550	300-32	300	485	140	35	M24	575	575
16	240 f6	245 m6	239.5	263	8	899	157	5	28	14	250	190	39	150	M20	2	250x5	240	245	380	550	320-32	320	520	140	35	M24	595	575
17	250 f6	260 m6	249.5	278	8	982	177	5	30	14	265	200	39	150	M20	2	265x5	250	260	415	600	340-32	340	570	155	35	M24	615	630
18	280 f6	285 m6	279.5	306	9	982	177	5	30	14	290	210	39	160	M20	2	290x5	280	285	415	600	360-32	360	590	162	35	M24	635	625
19	285 f6	295 m6	284.5	316	9	1100	187	5	32	15	300	220	39	170	M24	2	300x5	285	295	465	670	380-32	380	640	166	40	M27	-	-
20	310 f6	315 m6	309.5	336	9	1100	187	5	32	15	320	230	39	180	M24	2	320x6	310	315	465	670	390-32	390	650	166	40	M27	-	-
21	320 f6	335 m6	329	358	9	1160	205	5	40	20	340	250	45	190	M24	2	340x6	330	335	490	715	420-32	420	670	186	45	M27	-	-
22	340 f6	345 m6	339	360	9	1170	215	5	40	20	350	260	45	200	M24	2	350x6	340	345	490	725	440-32	440	720	194	45	M27	-	-



带平键联接的空心轴
类型 WV2
规格 4-18

Hollow Shafts for Parallal
Type WV2
Sizes 4-18

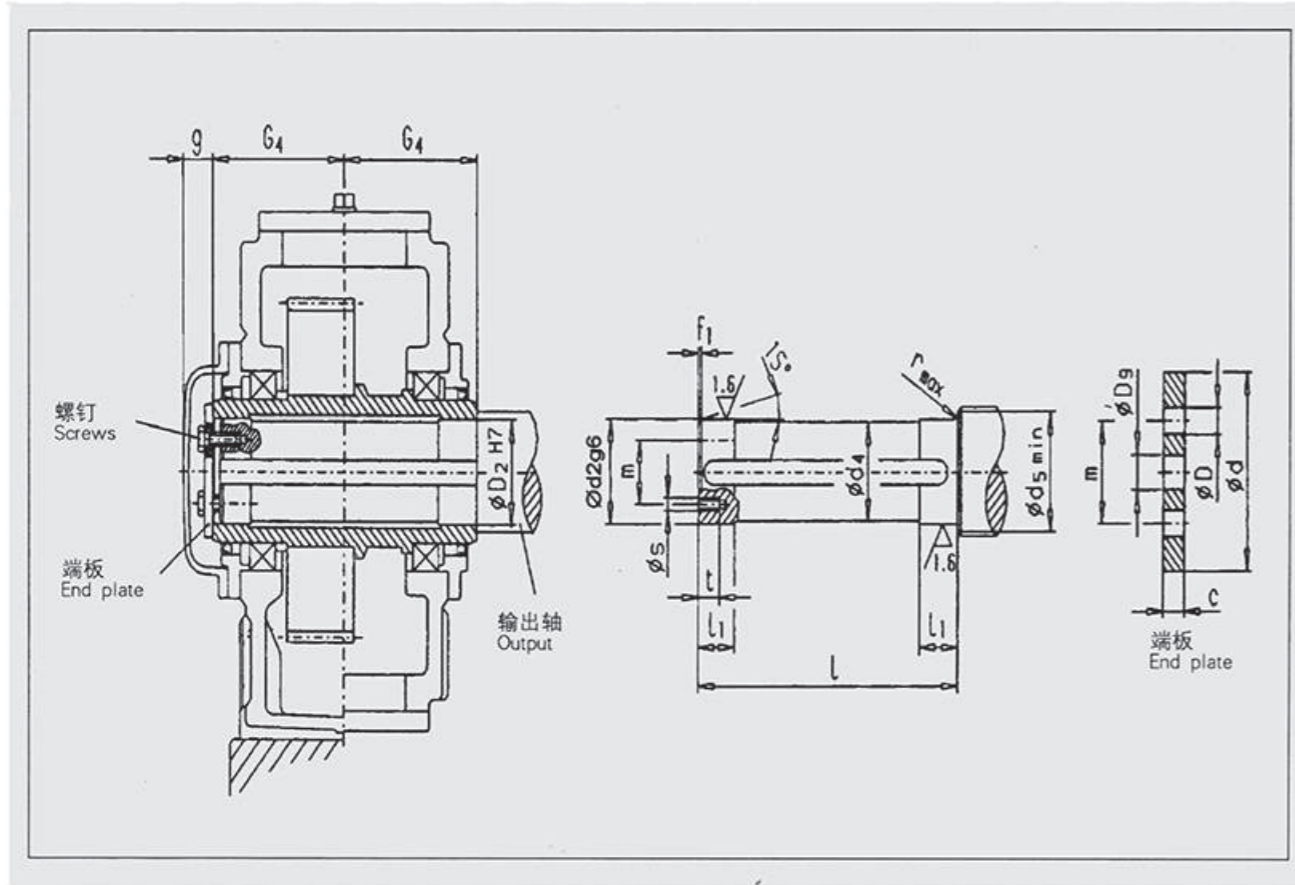

类型/type WV2H																			
齿轮箱规格 Gear Units Sizes	工作机驱动轴 Driven machine shaft										端板 End plate				螺钉 Screw		空心轴 Hollow shaft		
	d ₂	d ₄	d ₅	f ₁	l	l ₁	r	s	t	c	D	D ₉	d	m	规格/Size	数量/Qty	D ₂	G ₄	g
	mm																	mm	
4	80	79.5	88	4	338	35	1.2	M10	18	10	11	22	100	60	M10x25	2	80	170	35
5	95	94.5	105	5	398	40	1.6	M10	18	10	11	26	120	70	M10x25	2	95	200	40
6	105	104.5	116	5	398	45	1.6	M10	18	10	11	26	120	70	M10x25	2	105	200	40
7	115	114.5	126	5	468	50	1.6	M12	20	12	13.5	26	140	80	M12x30	2	115	235	40
8	125	124.5	136	6	468	55	2.5	M12	20	12	13.5	26	150	85	M12x30	2	125	235	40
9	135	134.5	147	6	537	60	2.5	M12	20	12	13.5	33	160	90	M12x30	2	135	270	45
10	155	149.5	162	6	537	65	2.5	M12	20	12	13.5	33	185	110	M12x30	2	150	270	45
11	165	164.5	177	7	637	70	2.5	M16	28	15	17.5	33	195	120	M16x40	2	165	320	45
12	180	179.5	192	7	637	75	2.5	M16	28	15	17.5	33	220	130	M16x40	2	180	320	45
14	210	209.5	226	8	777	85	3	M16	28	18	17.5	33	250	160	M16x40	2	210	390	45
16	240	239.5	258	8	896	100	3	M20	38	25	22	39	280	180	M20x55	4	140	450	60
18	275	274.5	295	9	1016	120	4	M20	38	25	22	39	330	210	M20x55	4	275	510	60



带平键联接的空心轴
类型 WH2, WH3, WH4, WV3, WV4
规格 4-18

Hollow Shafts for Parallal
Type WH2, WH3, WH4, WV3, WV4
Sizes 4-18

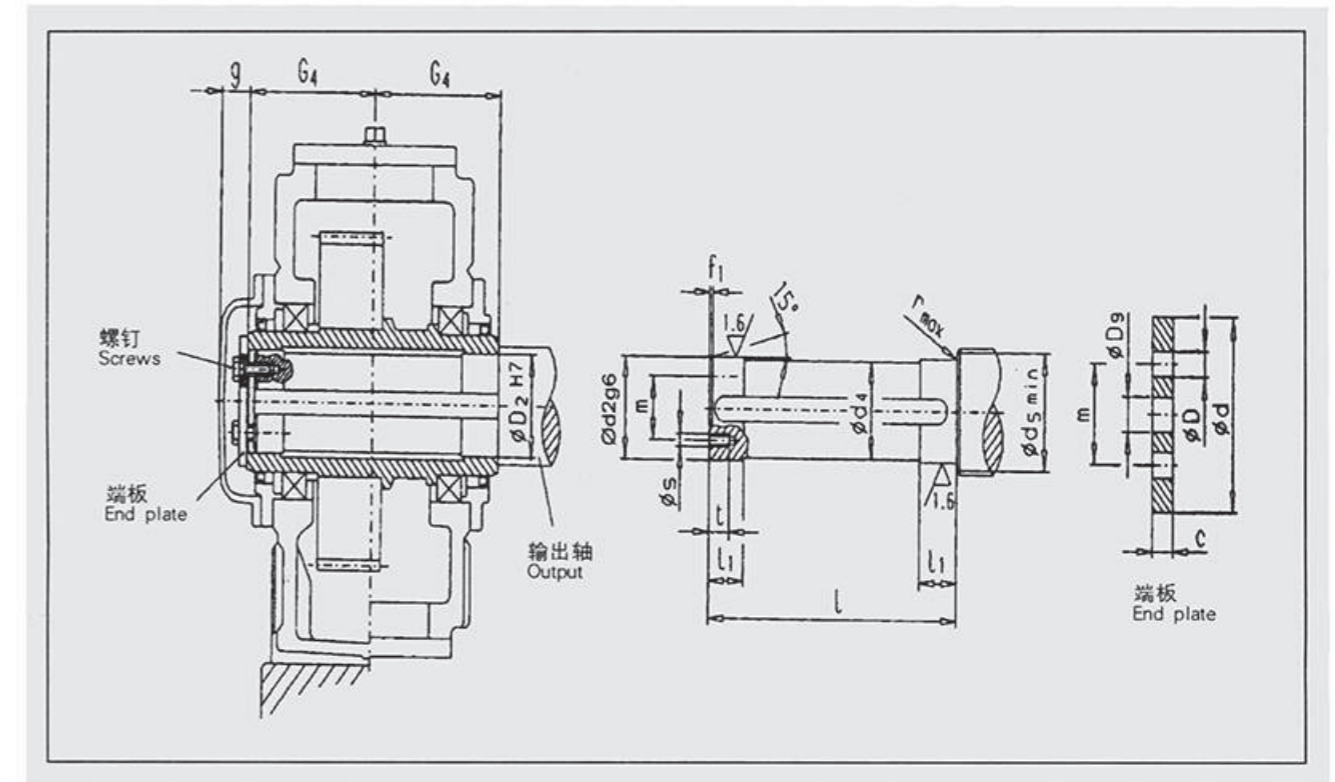

类型/type WH2H,WH3H,WH4H,WV3H,WV4H																			
齿轮箱规格 Gear Units Sizes	工作机驱动轴 Driven machine shaft										端板 End plate				螺钉 Screw		空心轴 Hollow shaft		
	d ₂	d ₄	d ₅	f ₁	l	l ₁	r	s	t	c	D	D ₉	d	m	规格/Size	数量/Qty	D ₂	G ₄	g
	mm																	mm	
4	80	79.5	88	4	278	35	1.2	M10	18	10	11	22	100	60	M10x25	2	80	140	35
5	95	94.5	105	5	328	40	1.6	M10	18	10	11	26	120	70	M10x25	2	95	165	40
6	105	104.5	116	5	328	45	1.6	M10	18	10	11	26	120	70	M10x25	2	105	165	40
7	115	114.5	126	5	388	50	1.6	M12	20	12	13.5	26	140	80	M12x30	2	115	195	40
8	125	124.5	136	6	388	55	2.5	M12	20	12	13.5	26	150	85	M12x30	2	125	195	40
9	135	134.5	147	6	467	60	2.5	M12	20	12	13.5	33	160	90	M12x30	2	135	235	45
10	150	149.5	162	6	467	65	2.5	M12	20	12	13.5	33	185	110	M12x30	2	150	235	45
11	165	164.5	177	7	537	70	2.5	M16	28	15	17.5	33	195	120	M16x40	2	165	270	45
12	180	179.5	192	7	537	75	2.5	M16	28	15	17.5	33	220	130	M16x40	2	180	270	45
13	190	189.5	206	7	667	80	3	M16	28	18	17.5	33	230	140	M16x40	2	190	335	45
14	210	209.5	226	8	667	85	3	M16	28	18	17.5	33	250	160	M16x40	2	210	335	45
15	230	229.5	248	8	756	100	3	M20	38	25	22	39	270	180	M20x55	4	230	380	60
16	240	239.5	258	8	756	100	3	M20	38	25	22	39	280	180	M20x55	4	240	380	60
17	250	249.5	270	8	826	110	4	M20	38	25	22	39	300	190	M20x55	4	250	415	60
18	275	274.5	295	9	826	120	4	M20	38	25	22	39	330	210	M20x55	4	275	415	60